

# Monoblok WARMHOMETECH EVI

House heating and cooling heat pump

( NT-9IISE NT-12IISE NT-17IISE NT-22IISE )

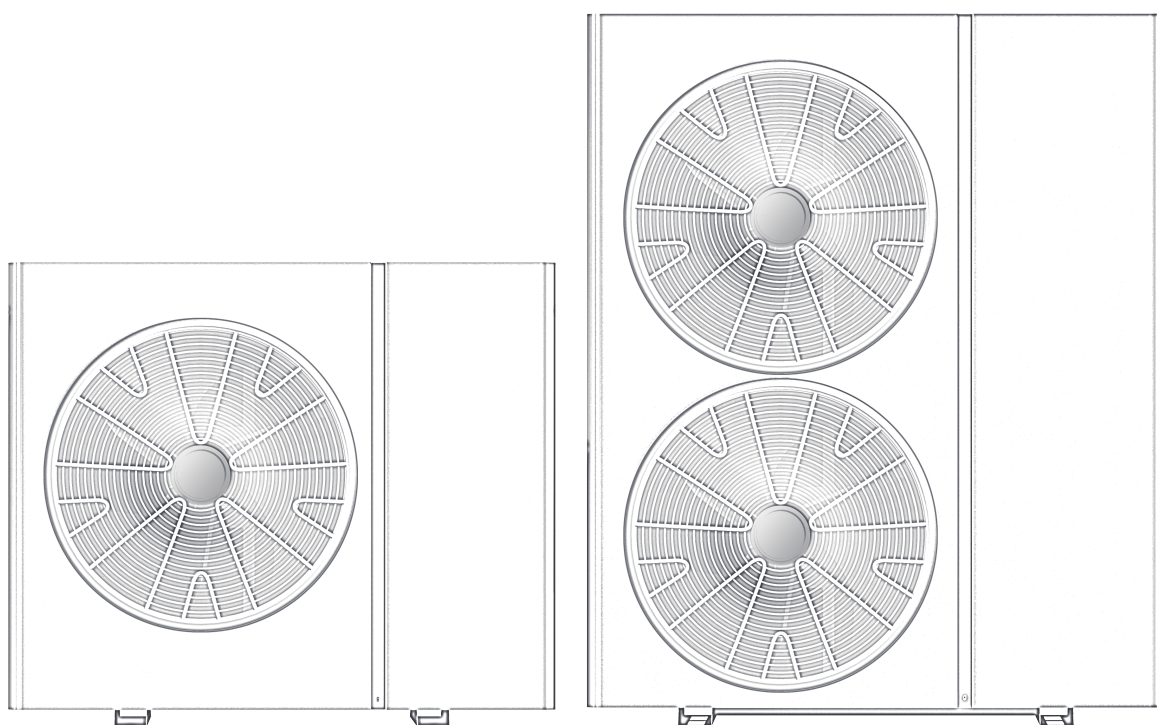

## INSTALLATION AND OPERATION MANUAL

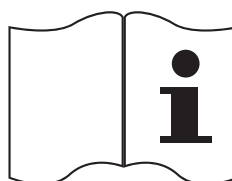
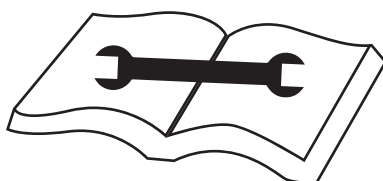
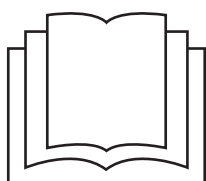



## Dear user:

Thank you for using our Air to Water heat pump!

This manual is for you to understand the installation, operation and maintenance of this unit, and to provide important safety information.

Please read all contents of this manual before installing and using this unit. Please keep this manual in a safe place for reference.

## Contents

<b>Caution &amp; Warning</b> .....	1
1. Safe instructions .....	7
1.1 Installation Precautions .....	7
2. Specifications .....	9
2.1 Performance data .....	9
2.2 Dimensions .....	10
2.3 Exploded view .....	11
3. Installation and connection .....	13
3.1 Heat pump location .....	13
3.2 Installation space requirements .....	13
3.3 General Applications .....	15
3.4 Electrical wiring .....	25
3.5 Wire system connection and wiring diagrams .....	26
4. Operation and use .....	28
4.1 Display interface introduction .....	28
4.2 Operating instructions .....	28
4.3 Error codes and troubleshooting .....	36
5. Maintenance and Inspection .....	38
6. Warranty .....	38

## WARNING

Do not use means to accelerate the defrosting process or to clean, other than those recommended by the manufacturer.

The appliance shall be stored in a room without continuously operating ignition sources (for example: open flames, an operating gas appliance or an operating electric heater).

Do not pierce or burn.

Be aware that refrigerants may not contain an odour.

1. The unit can only be repaired by qualified installer centre personnel or an authorized dealer.
2. This appliance is not intended for use by persons (including children from 8 years and above) with reduced physical sensory or mental capabilities, or lack of experience and knowledge, unless they have been given supervision or instruction concerning use of the appliance by a person responsible for their safety. Children should be supervised to ensure that they do not play with the appliance. Cleaning and user maintenance shall not be made by children without supervision.
3. Please make sure that the unit and power connection have good earthing, otherwise may cause electrical shock.
4. If the supply cord is damaged, it must be replaced by the manufacturer or our service agent or similarly qualified person in order to avoid a hazard.
5. Do not use means to accelerate the defrosting process or to clean, other than those recommended by the manufacturer.
6. The refrigerant used in this product meets the relevant requirements of EU.
7. Any person who is involved with working on or breaking into a refrigerant circuit should hold a current valid certificate from an industry-accredited assessment authority, which authorizes their competence to handle refrigerants safely in accordance with an industry recognized assessment specification.
8. The unit CANNOT be installed near the flammable gas. Once there is any leakage of the gas, fire can occur. Do not pierce or burn the appliance, otherwise the refrigerant will leak, leading to fire or explosion. Be aware that refrigerants may not contain an odour, please observe whether the refrigerant leaks carefully.
9. The appliance shall be stored in a well-ventilated area where the room size corresponds to the room area as specified for operation. And the room must be no continuously operating ignition sources (for example: open flames, an operating gas appliance or an operating electric heater.) The appliance shall be stored so as to prevent mechanical damage from occurring
10. The refrigerant used in the appliance is inflammable and explosive. Protective measures shall be taken when installing, repairing and cleaning. Open flames or an operating electric heater must be prohibited at the work site and well ventilation shall be maintained to prevent the accumulation of refrigerant in case of leakage.

In case of refrigerant leakage:

- (1) Turn off the power, remove the potential ignition source, evacuate the personnel and stay away from the scene.
  - (2) Emergency area shall be set within 20m away from the site, and irrelevant personnel are strictly prohibited to enter.
  - (3) After the danger is eliminated, open the ventilation facilities to remove the leakage point and the surrounding residual refrigerant
11. Servicing shall only be performed as recommended by the equipment manufacturer. Maintenance and repair requiring the assistance of other skilled personnel shall be carried out under the supervision of the person competent in the use of flammable refrigerants.
12. The service personnel who shall be instructed to undertake the following when servicing an appliance that employs a flammable refrigerant:
- (1) Checks to the area  
Prior to beginning work on systems containing flammable refrigerants, safety checks are necessary to ensure that the risk of ignition is minimized. For repair to the refrigerating system, the following precautions shall be complied with prior to conducting work on the system.
  - (2) Work procedure  
Work shall be undertaken under a controlled procedure so as to minimize the risk of a flammable gas or vapour being present while the work is being performed.
  - (3) General work area  
All maintenance staff and others working in the local area shall be instructed on the nature of work being carried out. Work in confined spaces shall be avoided. The area around the workspace shall be sectioned off. Ensure that the conditions within the area have been made safe by control of flammable material.
  - (4) Checking for presence of refrigerant  
The area shall be checked with an appropriate refrigerant detector prior to and during work, to ensure the technician is aware of potentially flammable atmospheres. Ensure that the leak detection equipment being used is suitable for use with flammable refrigerants, i.e. non sparking, adequately sealed or intrinsically safe.
  - (5) Presence of fire extinguisher  
If any hot work is to be conducted on the refrigeration equipment or any associated parts, appropriate fire extinguishing equipment shall be available to hand. Have a dry powder or CO2 fire extinguisher adjacent to the charging area.
  - (6) No ignition sources  
No person carrying out work in relation to a refrigeration system which involves exposing any pipe work that contains or has contained flammable refrigerant shall use any sources of ignition in such a manner that it may lead to the risk of fire or explosion. All possible ignition sources, including cigarette smoking, should be kept sufficiently far away from the site of installation, repairing, removing and disposal, during which flammable refrigerant can possibly be released to the surrounding space. Prior to work taking place, the area around the equipment is to be surveyed to make sure that there are no flammable hazards or ignition risks. "No Smoking" signs shall be displayed.

(7) Ventilated area

Ensure that the area is in the open or that it is adequately ventilated before breaking into the system or conducting any hot work. A degree of ventilation shall continue during the period that the work is carried out. The ventilation should safely disperse any released refrigerant and preferably expel it externally into the atmosphere.

(8) Checks to the refrigeration equipment

Where electrical components are being changed, they shall be fit for the purpose and to the correct specification. At all times the manufacturer's maintenance and service guidelines shall be followed. If in doubt consult the manufacturer's technical department for assistance.

The following checks shall be applied to installations using flammable refrigerants:

- The charge size is in accordance with the room size within which the refrigerant containing parts are installed;
- The ventilation machinery and outlets are operating adequately and are not obstructed;
- If an indirect refrigerating circuit is being used, the secondary circuit shall be checked for the presence of refrigerant;
- Marking to the equipment continues to be visible and legible. Markings and signs that are illegible shall be corrected;
- Refrigeration pipe or components are installed in a position where they are unlikely to be exposed to any substance which may corrode refrigerant containing components, unless the components are constructed of materials which are inherently resistant to being corroded or are suitably protected against being so corroded.

(9) Checks to electrical devices

Repair and maintenance to electrical components shall include initial safety checks and component inspection procedures. If a fault exists that could compromise safety, then no electrical supply shall be connected to the circuit until it is satisfactorily dealt with. If the fault cannot be corrected immediately but it is necessary to continue operation, an adequate temporary solution shall be used. This shall be reported to the owner of the equipment so all parties are advised. Initial safety checks shall include:

- That capacitors are discharged: this shall be done in a safe manner to avoid possibility of sparking;
- That no live electrical components and wiring are exposed while charging, recovering or purging the system.
- That there is continuity of earth bonding.

(10) Repairs to sealed components

- During repairs to sealed components, all electrical supplies shall be disconnected from the equipment being worked upon prior to any removal of sealed covers, etc. If it is absolutely necessary to have an electrical supply to equipment during servicing, then a permanently operating form of leak detection shall be located at the most critical point to warn of a potentially hazardous situation.
- Particular attention shall be paid to the following to ensure that by working on electrical components, the casing is not altered in such a way that the level of protection is affected. This shall include damage to cables, excessive number of connections, terminals not made to original specification, damage to seals, incorrect fitting of glands, etc.
- Ensure that apparatus is mounted securely.

- Ensure that seals or sealing materials have not degraded such that they no longer serve the purpose of preventing the ingress of flammable atmospheres. Replacement parts shall be in NOTE the use of silicon sealant may inhibit the effectiveness of some types of leak detection equipment. Intrinsically safe components do not have to be isolated prior to working on them.

### 13. Repair to intrinsically safe components

Do not apply any permanent inductive or capacitance loads to the circuit without ensuring that this will not exceed the permissible voltage and current permitted for the equipment in use.

Intrinsically safe components are the only types that can be worked on while live in the presence of a flammable atmosphere. The test apparatus shall be at the correct rating. Replace components only with parts specified by the manufacturer. Other parts may result in the ignition of refrigerant in the atmosphere from a leak.

### 14. Cabling

Check that cabling will not be subject to wear, corrosion, excessive pressure, vibration, sharp edges or any other adverse environmental effects. The check shall also take into account the effects of ageing or continual vibration from sources such as compressors or fans.

### 15. Detection of flammable refrigerants

Under no circumstances shall potential sources of ignition be used in the searching for or detection of refrigerant leaks. A halide torch (or any other detector using a naked flame) shall not be used.

### 16. Leak detection methods

The following leak detection methods are deemed acceptable for systems containing flammable refrigerants.

Electronic leak detectors shall be used to detect flammable refrigerants, but the sensitivity may not be adequate, or may need re-calibration. (Detection equipment shall be calibrated in a refrigerant-free area.) Ensure that the detector is not a potential source of ignition and is suitable for the refrigerant used. Leak detection equipment shall be set at a percentage of the LFL of the refrigerant and shall be calibrated to the refrigerant employed and the appropriate percentage of gas (25 % maximum) is confirmed. Leak detection fluids are suitable for use with most refrigerants but the use of detergents containing chlorine shall be avoided as the chlorine may react with the refrigerant and corrode the copper pipe-work. If a leak is suspected, all naked flames shall be removed/extinguished. If a leakage of refrigerant is found which requires brazing, all of the refrigerant shall be recovered from the system, or isolated (by means of shut off valves) in a part of the system remote from the leak. Oxygen free nitrogen (OFN) shall then be purged through the system both before and during the brazing process.

### 17. Removal and evacuation

When breaking into the refrigerant circuit to make repairs – or for any other purpose – conventional procedures shall be used. However, it is important that best practice is followed since flammability is a consideration. The following procedure shall be adhered to:

- (1) Remove refrigerant;
- (2) Purge the circuit with inert gas;
- (3) Evacuate;
- (4) Purge again with inert gas;
- (5) Open the circuit by cutting or brazing.

The refrigerant charge shall be recovered into the correct recovery cylinders. The system shall be "flushed" with OFN to render the unit safe. This process may need to be repeated several times. Compressed air or oxygen shall not be used for this task. Flushing shall be achieved by breaking the vacuum in the system with OFN and continuing to fill until the working pressure is achieved, then venting to atmosphere, and finally pulling down to a vacuum. This process shall be repeated until no refrigerant is within the system. When the final OFN charge is used, the system shall be vented down to atmospheric pressure to enable work to take place. This operation is absolutely vital if brazing operations on the pipe-work are to take place. Ensure that the outlet for the vacuum pump is not close to any ignition sources and there is ventilation available.

#### 18. Charging procedures

In addition to conventional charging procedures, the following requirements shall be followed.

- (1) Ensure that contamination of different refrigerants does not occur when using charging equipment. Hoses or lines shall be as short as possible to minimize the amount of refrigerant contained in them;
- (2) Cylinders shall be kept upright;
- (3) Ensure that the refrigeration system is earthed prior to charging the system with refrigerant;
- (4) Label the system when charging is complete (if not already).

Extreme care shall be taken not to overfill the refrigeration system.

Prior to recharging the system it shall be pressure tested with OFN. The system shall be leak tested on completion of charging but prior to commissioning. A follow up leak test shall be carried out prior to leaving the site.

#### 19. Decommissioning

Before carrying out this procedure, it is essential that the technician is completely familiar with the equipment and all its detail. It is recommended good practice that all refrigerants are recovered safely. Prior to the task being carried out, an oil and refrigerant sample shall be taken in case analysis is required prior to re-use of reclaimed refrigerant. It is essential that electrical power is available before the task is commenced.

- (1) Become familiar with the equipment and its operation.
- (2) Isolate system electrically.
- (3) Before attempting the procedure ensure that:
  - Mechanical handling equipment is available, if required, for handling refrigerant cylinders;
  - All personal protective equipment is available and being used correctly;
  - The recovery process is supervised at all times by a competent person;
  - Recovery equipment and cylinders conform to the appropriate standards.
- (4) Pump down refrigerant system, if possible.
- (5) If a vacuum is not possible, make a manifold so that refrigerant can be removed from various parts of the system.
- (6) Make sure that cylinder is situated on the scales before recovery takes place.
- (7) Start the recovery machine and operate in accordance with manufacturer's instructions.
- (8) Do not overfill cylinders. (No more than 80 % volume liquid charge).
- (9) Do not exceed the maximum working pressure of the cylinder, even temporarily.
- (10) When the cylinders have been filled correctly and the process completed, make sure that the cylinders and the equipment are removed from site promptly and all isolation valves on the equipment are closed off.

(11) Recovered refrigerant shall not be charged into another refrigeration system unless it has been cleaned and checked.

20. Labelling

Equipment shall be labelled stating that it has been de-commissioned and emptied of refrigerant. The label shall be dated and signed. Ensure that there are labels on the equipment stating the equipment contains flammable refrigerant.

21. Recovery

When removing refrigerant from a system, either for servicing or decommissioning, it is recommended good practice that all refrigerants are removed safely.

22. Electrical Wiring

The appliance shall be installed in accordance with national wiring regulations. Make sure that there is a circuit breaker for the unit, lack of a circuit breaker can lead to electrical shock or fire.

**Air source heat pump winter anti-freezing measurements:**

- Strengthen the insulation material of piping;
- Condensate water should be properly disposed off;
- For NT-17IISE / NT-22IISE: When it will not be used for a long time during winter, add a three way pipe and ball valve for inlet and outlet respectively to drain water off the system and piping.
- For NT-9IISE / NT-12IISE: When it will not be used for a long time during winter, add a three way pipe and ball valve at the outlet. To drain off water, turn on the ball valve and turn the drain valve located on the bottom counterclockwise simultaneously;

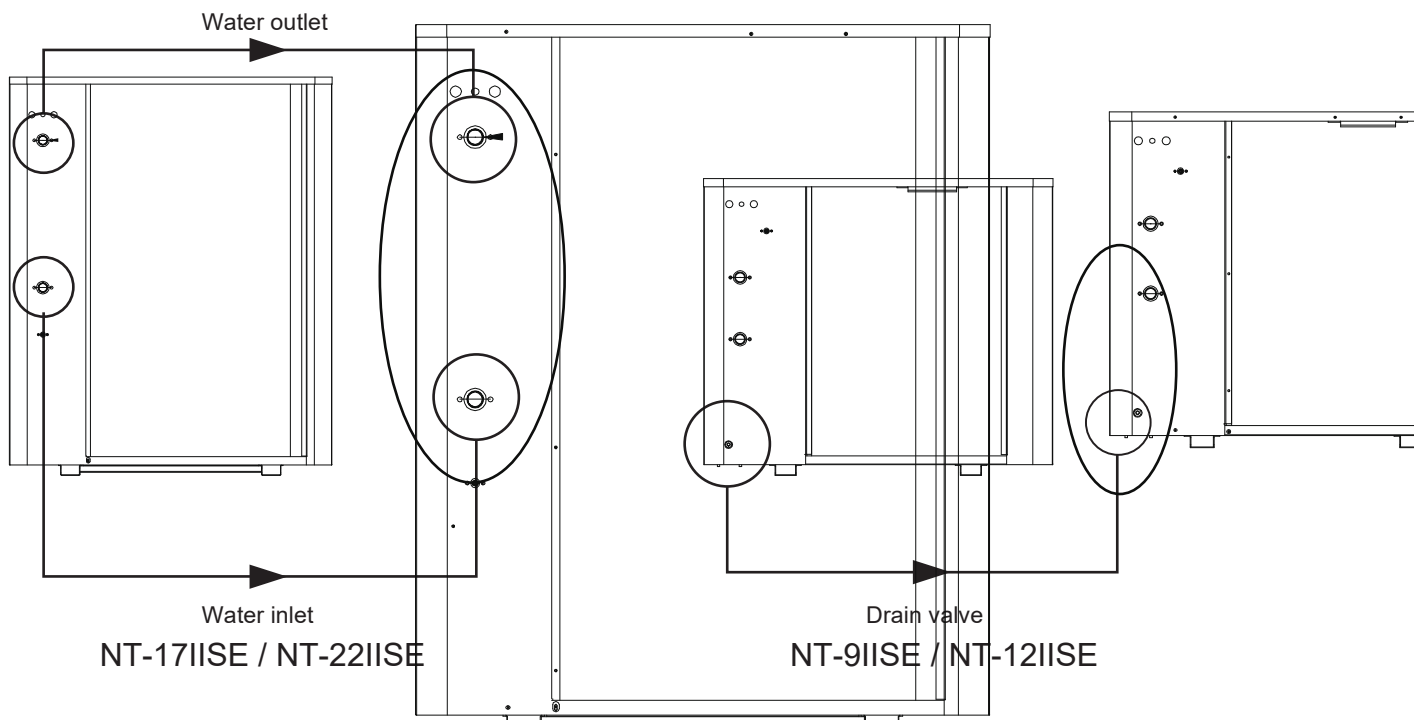

- Clear debris and snow around the heat pump in time

- Add antifreeze to the system, details please refer to following instruction:

If antifreeze is added, the following possible conditions must be noted, depending on the concentration of the mixture:

- (1) The heat output of the heat pump decreases;
- (2) COP reduction;
- (3) Reduced delivery rate of on-site circulation pump; free pressure drop specified for integrated circulation pump;
- (4) Compatibility of component materials used with antifreeze mixtures must be ensured;

Note:

For system antifreeze, it is best to use antifreeze specially designed for heat pumps. Considering the corrosion resistance of water pumps, filter valves as well as the thermal performance of the heat pump, we suggest that the concentration of glycol should not exceed 30%.

# 1.Safety instructions

## 1.1 Installation Precautions

Please make sure that you have at least read the "safety instructions" chapter of this manual before using the air source unit of our company. The "safety instructions" provides very important safety tips and key points of unit use. Please make sure that you follow the instructions to ensure personal safety and normal operation of the unit.

### The meaning of symbols used in the text:



Warning

Serious consequences such as death, serious injury or major accident may occur due to incorrect use and operation.



Notice

Improper use may cause safety accidents, damage the machine or affect the use of the machine.

Please read the label on the heat pump carefully. If any abnormality is found during use, such as abnormal noise, smell, smoke, temperature rise, electric leakage, fire, etc., please cut off the power supply immediately and contact the local agent of the company in time. Do not repair by yourself. If necessary, contact the local fire and first aid department immediately.



Warning

- 1) The unit shall not be installed by users, but must be installed by agents or professional installation companies, otherwise it may cause safety accidents and affect the use effect.
- 2) Do not disassemble the machine without authorization unless you are instructed by professionals, otherwise accidents or damage to the machine may occur.
- 3) Do not use or store flammables such as hair gel, paint, gasoline and alcohol, etc. around the machine, otherwise there is the possibility of fire.
- 4) The master power switch of the unit should be placed in a place out of reach of children to prevent the danger of children playing with the power switch.
- 5) Do not spray water or other liquids on the unit, otherwise danger may occur.
- 6) Do not operate the machine with wet hands, otherwise it may cause danger.
- 7) In thunderstorm weather, please turn off the master power switch of the machine, otherwise lightning may cause danger or damage the machine.

- 8) The unit shall use independent power supply to avoid sharing the same circuit with other electrical appliances; It is recommended to use separate lines and circuit breakers with leakage protection.
- 9) The unit belongs to class I electrical appliances. The power supply must have a reliable grounding wire. Do not connect the grounding wire with the grounding wire of gas pipeline, water pipe, lightning conductor or telephone, so as to avoid accidents.
- 10) Do not forcibly cut off the power supply when the unit is running to avoid accidents.
- 11) The installation space of the unit shall be well ventilated to ensure that once there is refrigerant leakage, it can be dissipated in time. At the same time, there is no fire source around the installation position, such as heater, stove, etc., otherwise the refrigerant may contact the fire source, which may produce toxic gas or combustion, which is very easy to cause personnel poisoning, fire accidents, etc.



#### Notice

- 1) Household power supply and circuit meet relevant standards.
- 2) The power circuit is equipped with leakage protector.
- 3) The power cord is not damaged. If there is any damage, please contact the relevant dealer or professional for replacement.
- 4) The unit shall be installed firmly without violent vibration and noise interference to neighbors.
- 5) The drainage piping can drain smoothly. It will not cause water leakage, wet furniture, etc.
- 6) Do not store the machine in a humid environment or expose it to rain, otherwise it is very easy to damage the machine after installation.
- 7) When the machine is not used for a long time, please disconnect the master power switch and empty the waterway at the same time to avoid accidents.

## 1.2 Other Safety Considerations

- 1) Please read all "safety precautions" carefully before operating the unit.
- 2) All important safety-related matters listed in "Safety Precautions" are requested to be strictly observed.
- 3) The unit must use a fuse of the specified capacity, which can't be replaced by iron wire or copper wire.
- 4) The working environment of the unit shall be far away from the place with potential fire hazards. If the line problem causes a fire, turn off the master power switch immediately and put out the fire with dry powder fire extinguisher.
- 5) The power supply must be cut off before unit maintenance.
- 6) Sharp edges and fin surfaces are harmful and should be avoided as far as possible.
- 7) It is forbidden to place objects above the unit to avoid accidents caused by falling objects when the machine is running.
- 8) The fixed line connected to the equipment must be equipped with a full pole disconnecting device with a contact opening distance of at least 3mm.
- 9) The equipment shall be installed in accordance with the national wiring rules.

## 2.Specifications

### 2.1Performance data

Model		NT-9IISE	NT-12IISE	NT-17IISE	NT-22IISE
Power supply	V/Ph/Hz	380-415V,3N~,50Hz			
Featurers		Heating/Cooling/Inverter			
Functions		Boost/Eco			
Refrigerant		R32			
Heating:	Capacity(kw)	9.10	12.00	16.80	22.00
(Air 7/6°C Inlet/Outlet	Power input(kw)	2.74	3.57	4.86	5.90
water 40/45°C)	COP ( W/W )	3.32	3.36	3.46	3.73
Heating :	Capacity(kw)	7.00	8.00	14.05	15.48
(Air -12°C Inlet/Outlet	Power input(kw)	2.93	3.29	5.30	5.61
water 36/41°C)	COP ( W/W )	2.39	2.43	2.65	2.76
Cooling:	Capacity(kw)	6.90	8.20	13.35	16.76
(Air 35/24°C Inlet/Outlet	Power input(kw)	2.40	2.69	4.02	5.02
water 12/7°C)	EER ( W/W )	2.88	3.05	3.32	3.34
Operating inlet	Heating	°C		8-55	
water temp.	Cooling	°C		8-28	
Water inlet pressure range	Mpa	0-0.5			
Auxiliary electric heater	kw	3			
Max input current	A	13.3	14.3	17	17.5
Circuit breaker	A	16	20	25	25
Power cord	mm <sup>2</sup>	5*2.5	5*2.5	5*4	5*4
Max input power(heat pump)	kw	3.62	4.41	6.17	6.25
Refrigerant charge volume	Kg	1.3	1.6	2	2.5
CO2 equivalent	TON	0.88	1.08	1.35	1.69
Operating ambient temp.	°C	-28 ~ 43			
Compressor type		EVI Twin-rotary DC inverter			
Fan type		DC motor fan-Horizontal			
Sound pressure	dB(A)	≤ 55	≤ 57	≤ 60	≤ 61
Water pump		Included			
Heat exchanger	Type	Plate heat exchanger			
	Water pressure drop(kPa)	10	15	15	20
	Connection size(Inch)	G1			
Advised water flow	m <sup>3</sup> /h	≥1.35	≥1.35	≥2.2	≥2.6
Unit dimensions(W*D*H)	mm	1002*405*845		1043*405*1266	
Net weight	Kg	77.5	80	116	119

\*The above data is for reference only.

For more specific data, please refer to the product nameplate.

## 2.2 Dimensions

NT-9IISE/12IISE ( unit:mm )

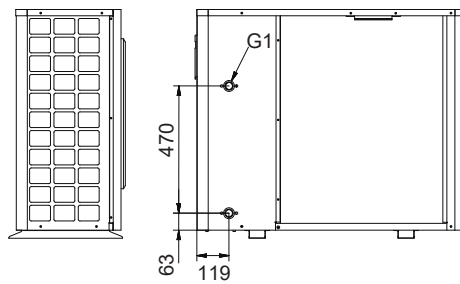
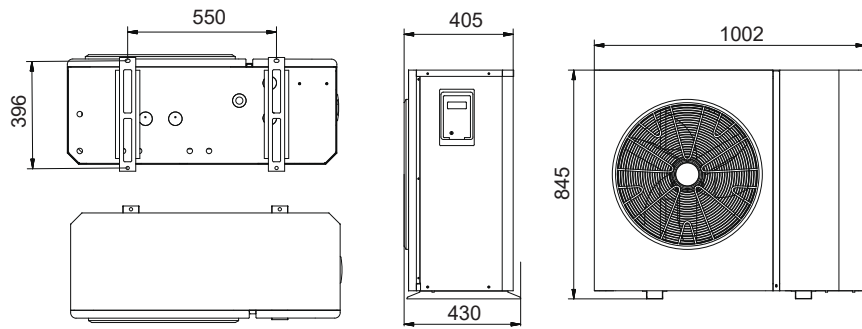

NT-17IISE/22IISE ( unit:mm )

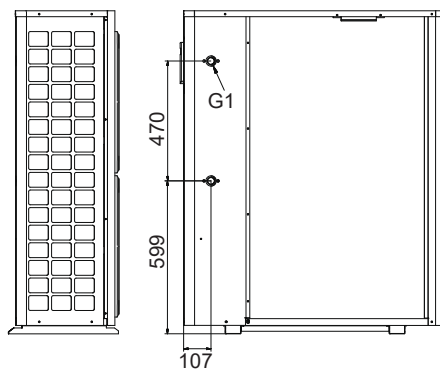
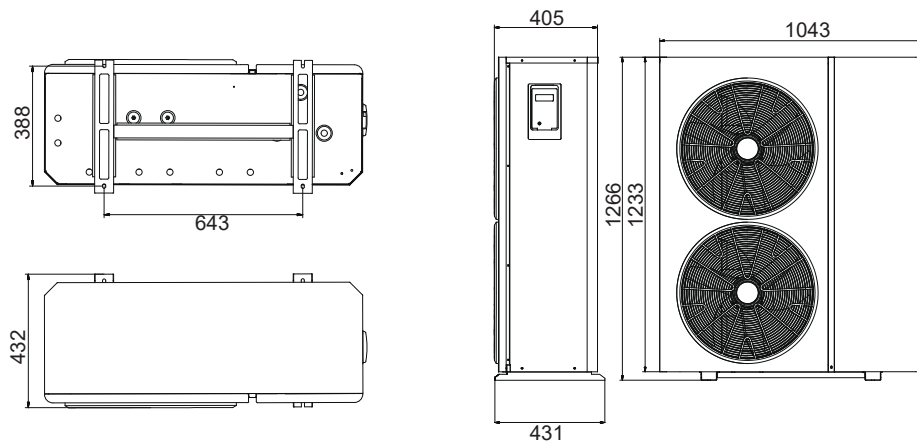

## 2.3 Exploded view

NT-9IISE/12IISE

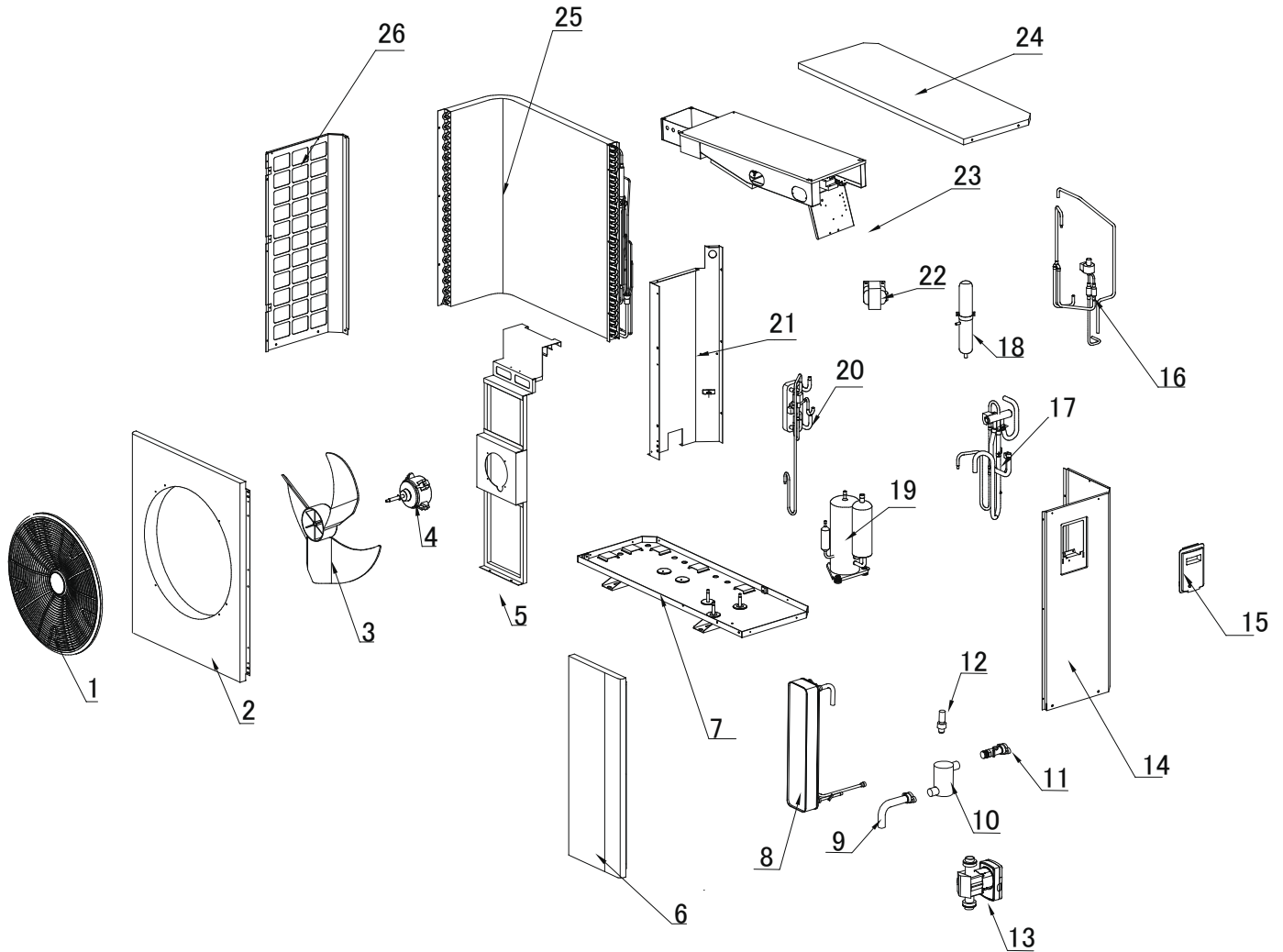

No.	Components	No.	Components	No.	Components
1	Air outlet grill	10	Auxiliary electric heater	19	Compressor
2	Front panel	11	PHE outlet pipe	20	Economizer
3	Axial fan blade	12	Water switch	21	Vertical bracket
4	DC fan motor	13	Water pump	22	Reactor
5	Motor bracket	14	Right panel	23	Electric control
6	Front right panel	15	Plastic baffle	24	Top panel
7	Chassis	16	Solenoid valve	25	Outdoor heat exchanger
8	PHE components	17	Four-way valve	26	Left panel
9	PHE inlet pipe	18	Gas storage tank		

NT-17IISE/22IISE

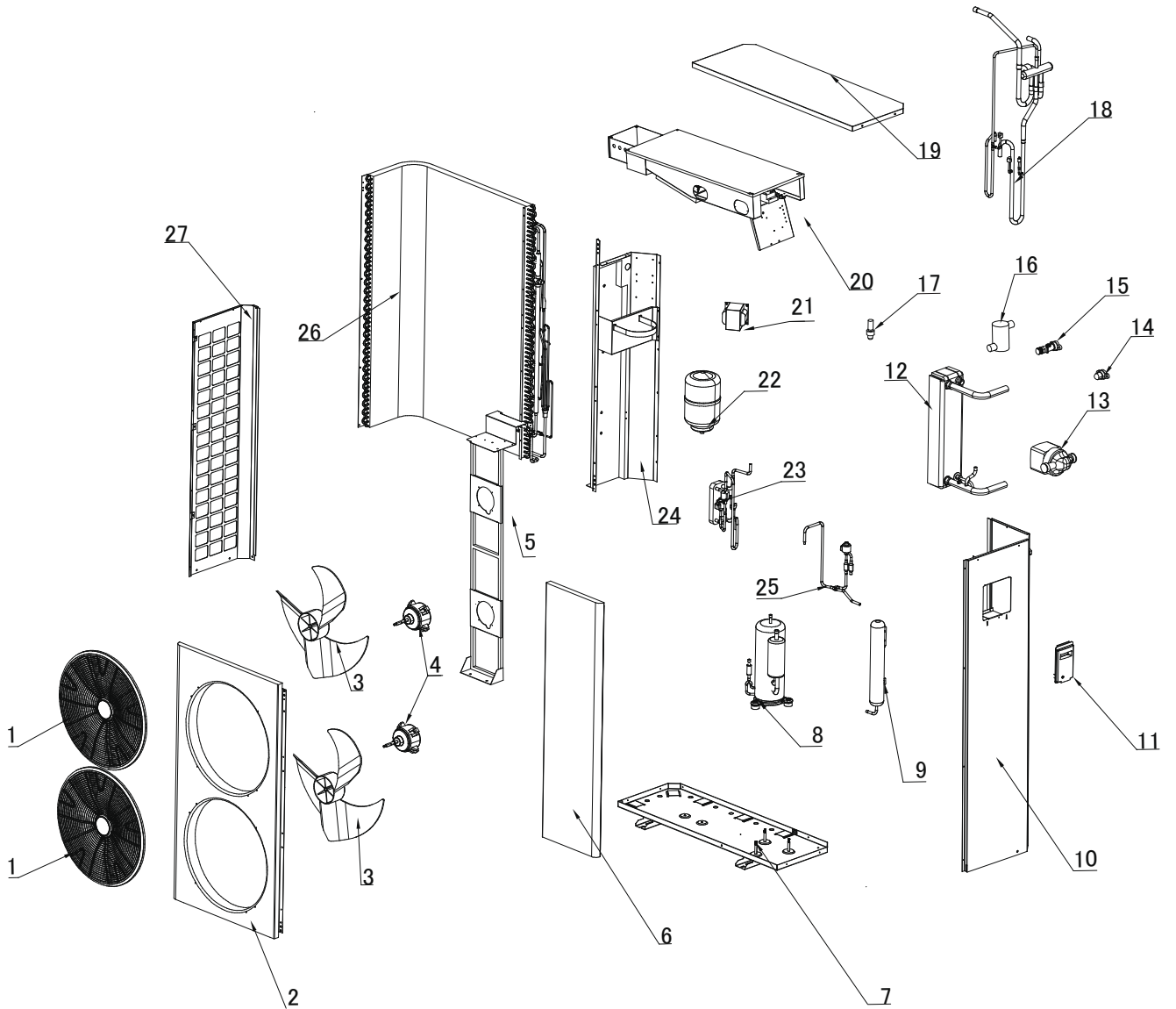

No.	Components	No.	Components	No.	Components
1	Air outlet grill	10	Right panel	19	Top panel
2	Front panel	11	Plastic baffle	20	Electric control
3	Axial fan blade	12	PHE components	21	Reactor
4	DC fan motor	13	Water pump	22	Expansion tank
5	Motor bracket	14	PHE inlet pipe	23	Economizer
6	Front right panel	15	PHE outlet pipe	24	Vertical bracket
7	Chassis	16	Auxiliary electric heater	25	Solenoid valve
8	Compressor	17	Water switch	26	Outdoor heat exchanger
9	Gas storage tank	18	Four-way valve	27	Left panel

## 3. Installation and connection



### Notice

Installation in the following places may lead to machine failure (if unavoidable, please consult the relevant dealer):

- 1) Where there is mineral oil such as cutting oil.
- 2) In places where the air contains more salt, such as the seaside.
- 3) In hot spring areas and other places where corrosive gases such as sulfur gas exist.
- 4) Where the power supply voltage fluctuates seriously.
- 5) Places such as cars or cabins.
- 6) Kitchens and other places where there are lots of fumes and oil gas.
- 7) Where there are strong electromagnetic waves.
- 8) Where flammable gases or materials are present.
- 9) Where there is evaporation of acidic or alkaline gases.
- 10) Other special environmental conditions.

### 3.1 Heat pump location

- 1) The outdoor unit can be installed on the unsealed balcony or external wall; At the same time, please take waterproof measures.
- 2) It can provide enough space for installation and maintenance.
- 3) The air inlet and outlet of the outdoor unit are unobstructed.
- 4) Dry and well ventilated, and avoid places where flammable and explosive gases are easy to leak and environments with strong corrosive gases.
- 5) Easy to install connecting pipes and electrical lines.
- 6) The support surface is flat and can bear the weight of the outdoor unit. The outdoor unit can be installed horizontally without increasing vibration and noise. If the foundation is a metal part, it must be insulated and comply with relevant technical standards.
- 7) Running noise and discharging cold air will not affect yourself and others.
- 8) Avoid places directly affected by strong electric and magnetic fields.

### 3.2 Installation space requirements

Installation in the following places may lead to machine failure (if unavoidable, please consult the relevant dealer):

During installation, please reserve enough installation space to avoid affecting the performance of the unit. At the same time, it is convenient for later maintenance.



### Notice

\*Please have qualified dealers or designated professional technicians to be responsible for installation.

\*Improper self installation may lead to water leakage,electric leakage, fire, unit falling and other accidents.

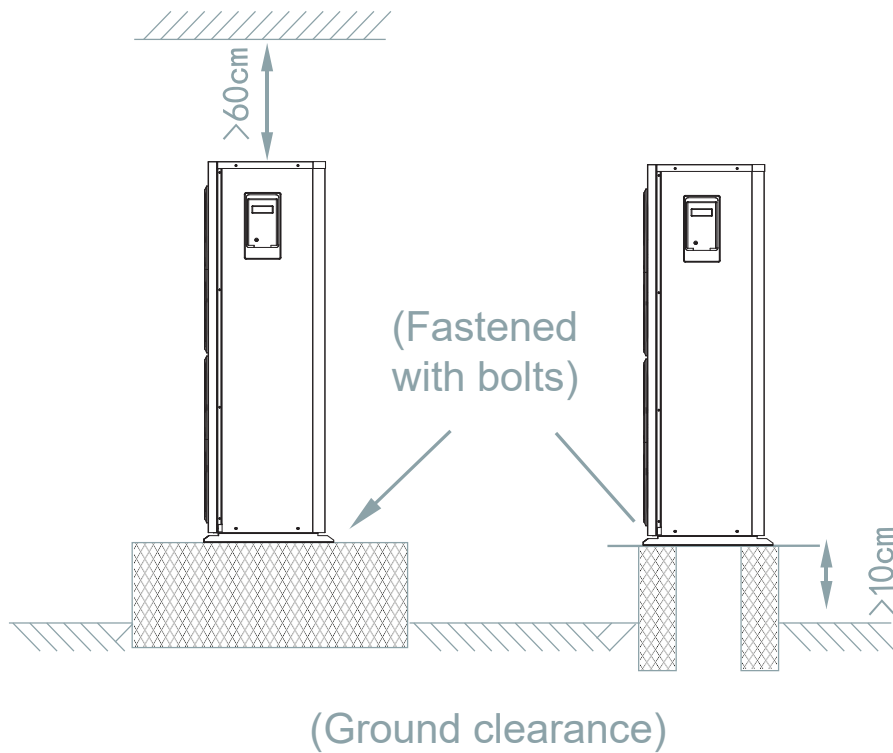
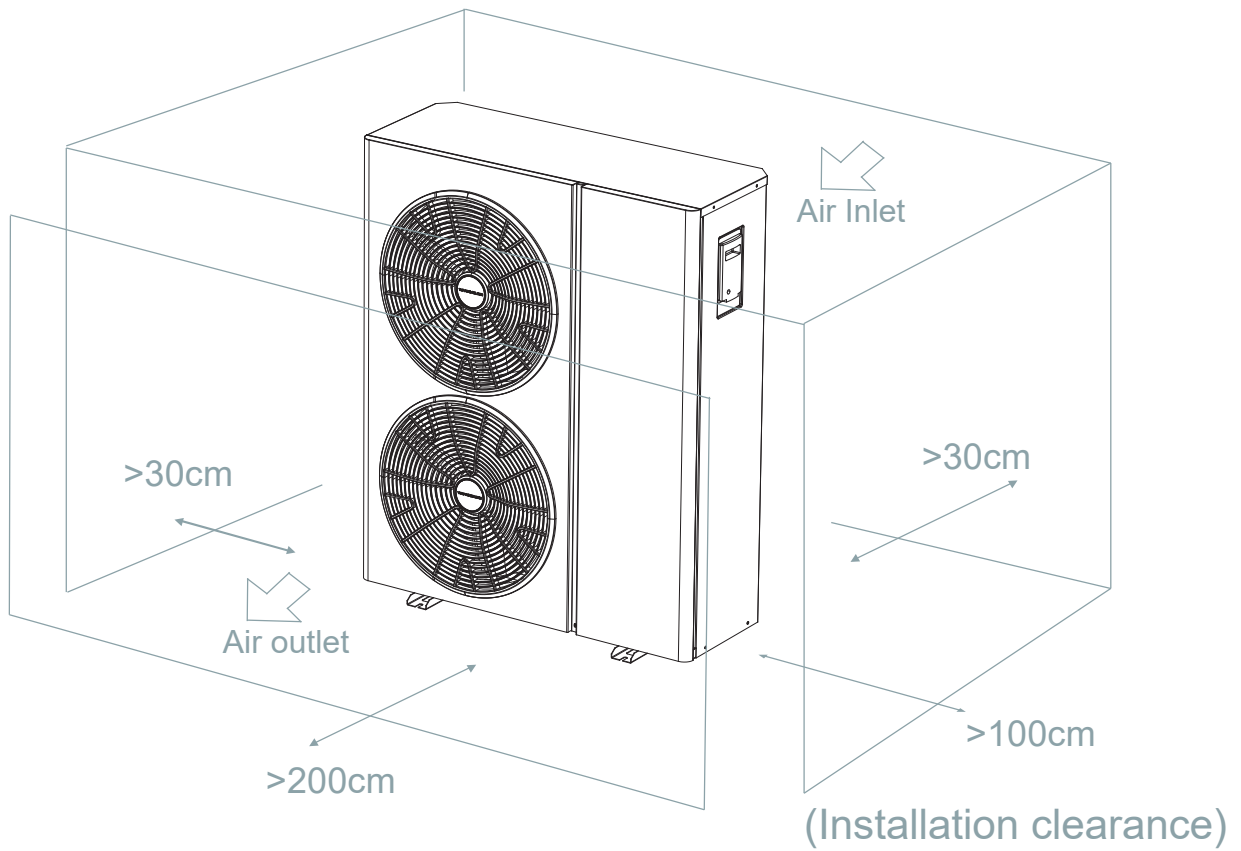

### 3.3 General Applications :

#### 3.3.1 Heating only function

This application is recommended for using heating (floor/radiator/fan coil) only purposes.

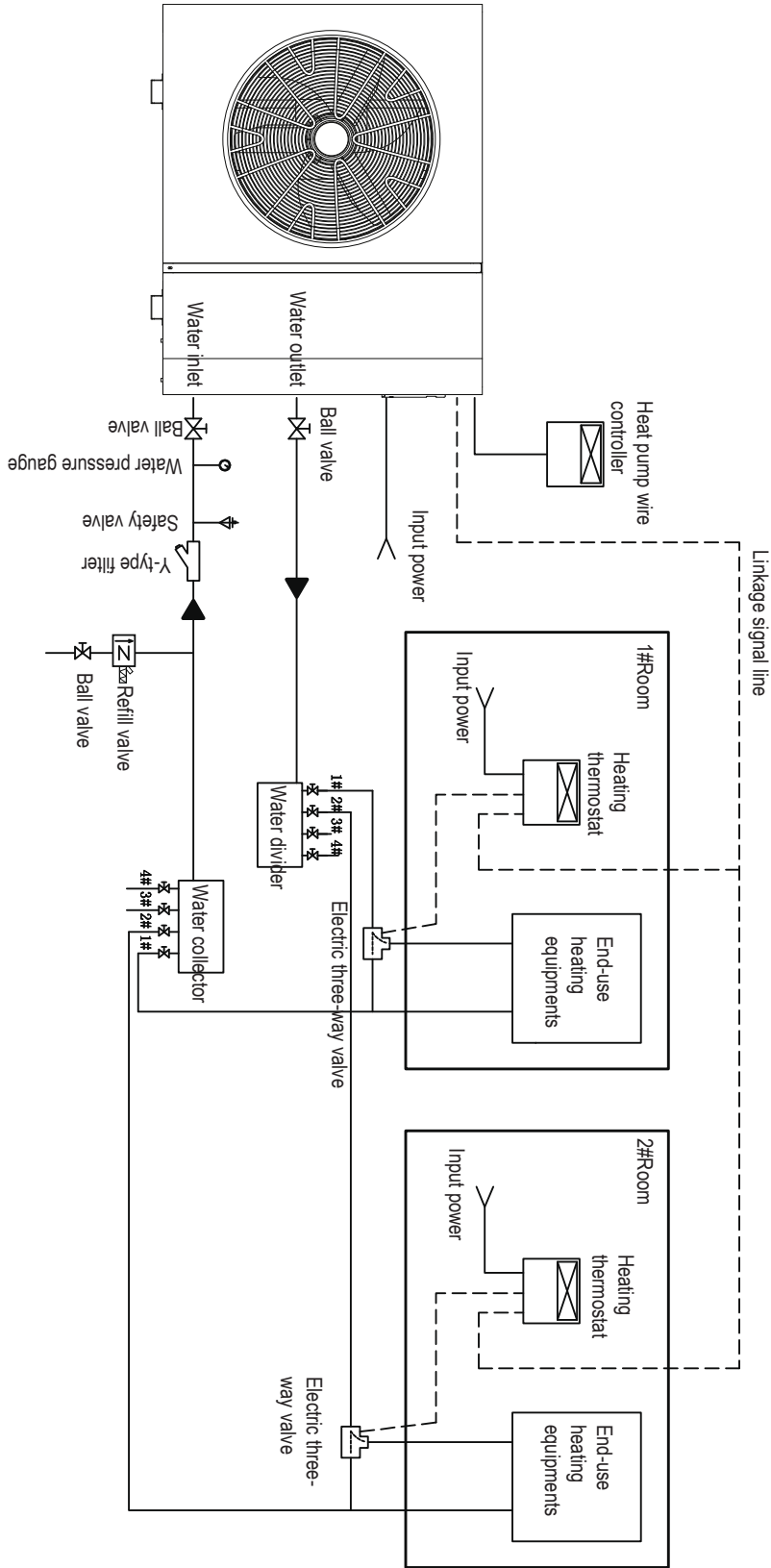

Remark:

1. The water divider and water collector are used for water distribution when multiple end-use heating equipments are installed at the same time.
2. After connected to the linkage signal line, each individual thermostat can control the operation or shutdown of the heat pump. If didn't connect to the linkage signal line, the heat pump will operate until the shutdown conditions of the heat pump are met (whether the end-use heating is using or not).
3. The schematic diagram mainly provides the necessary pipeline accessories. Other accessories may need to be added according to the actual site engineering installation situation.

### 3.3 General Applications :

#### 3.3.2 Heating + hot water function

This application is recommended for using heating (floor/radiator/fan coil) and DHW purposes with a low cost of installation.

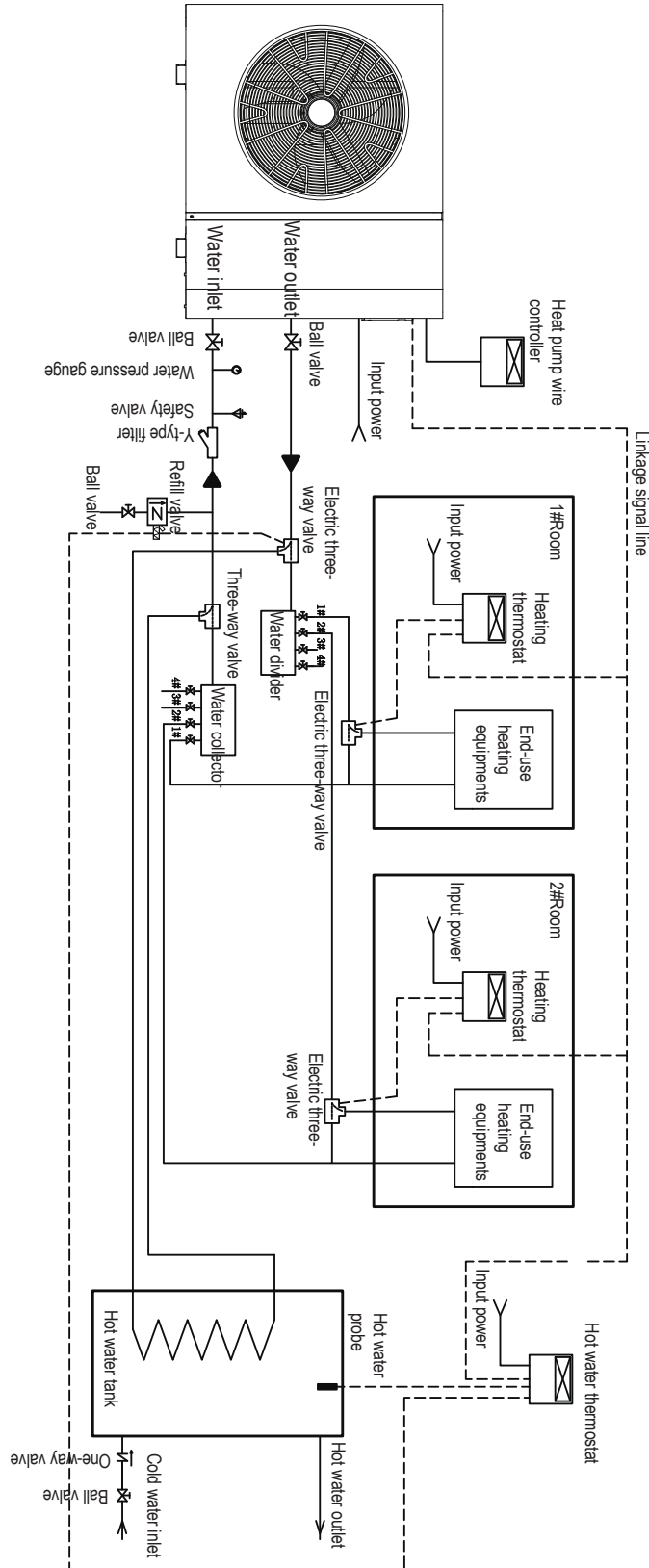

Remark:

1. The water divider and water collector are used for water distribution when multiple end-use heating equipments are installed at the same time.
2. After connected to the linkage signal line, each individual thermostat can control the operation or shutdown of the heat pump. If didn't connect to the linkage signal line, the heat pump will operate until the shutdown conditions of the heat pump are met (whether the end-use heating is using or not).
3. The DHW function only available under the heating mode.
4. Adding a hot water thermostat can control the temperature of the hot water tank, if only the heat pump is used for heating, the maximum DHW temperature can reach the set temperature of the heat pump at most.
5. The schematic diagram mainly provides the necessary pipeline accessories. Other accessories may need to be added according to the actual site engineering installation situation.

### 3.3 General Applications :

#### 3.3.3 Heating + hot water function

This application is recommended for using heating (floor/radiator/fan coil) and DHW purposes with needs of a high DHW temperature.

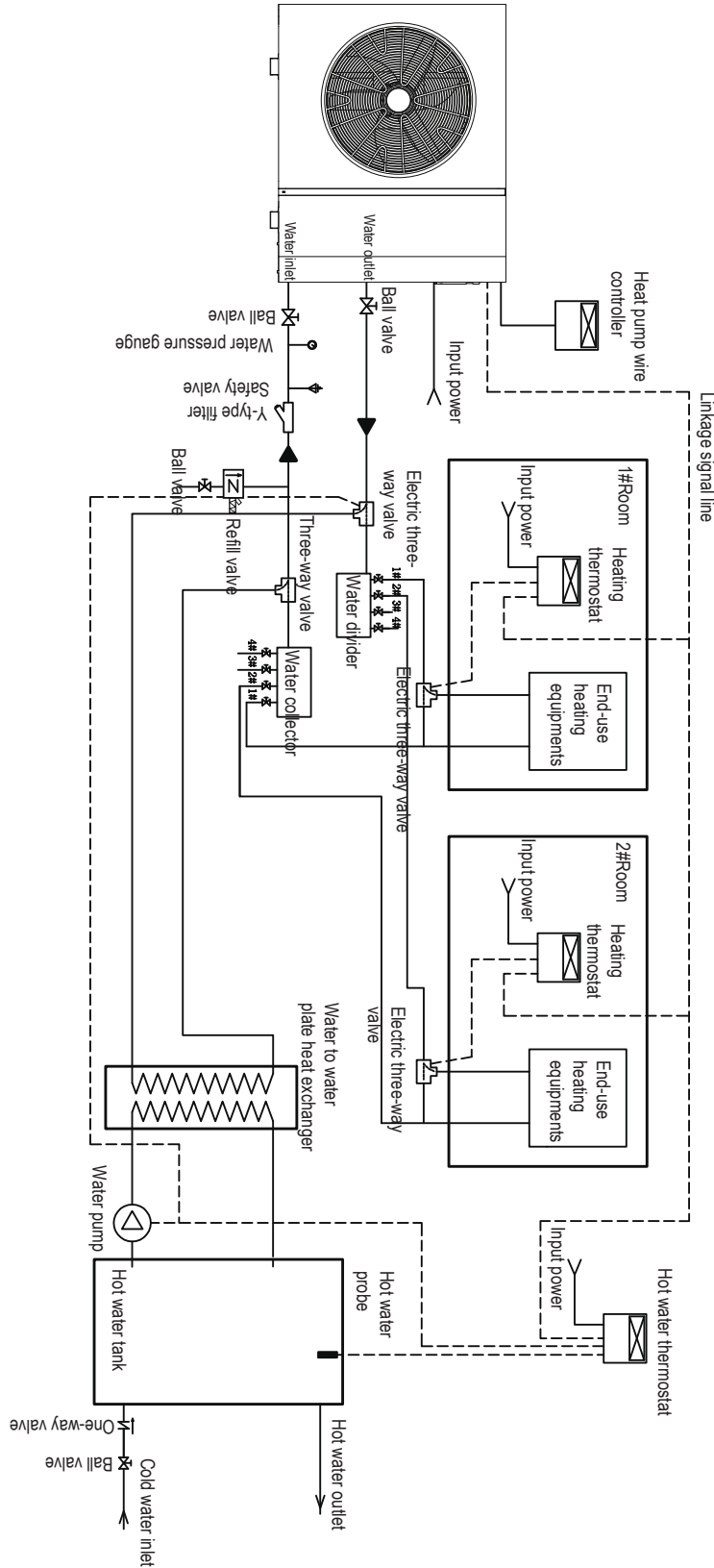

Remark:

1. The water divider and water collector are used for water distribution when multiple end-use heating equipments are installed at the same time.
2. After connected to the linkage signal line, each individual thermostat can control the operation or shutdown of the heat pump. If didn't connect to the linkage signal line, the heat pump will operate until the shutdown conditions of the heat pump are met (whether the end-use heating is using or not).
3. The DHW function only available under the heating mode.
4. Adding a hot water thermostat can control the temperature of the hot water tank, if only the heat pump is used for heating, the maximum DHW temperature can reach the set temperature of the heat pump at most.
5. The schematic diagram mainly provides the necessary pipeline accessories. Other accessories may need to be added according to the actual site engineering installation situation.

### 3.3 General Applications :

#### 3.3.4 Heating + hot water function (Solar Panel-optional)

This application is recommended for using heating (floor/radiator/fan coil) and DHW purposes with a solar panel heating source.

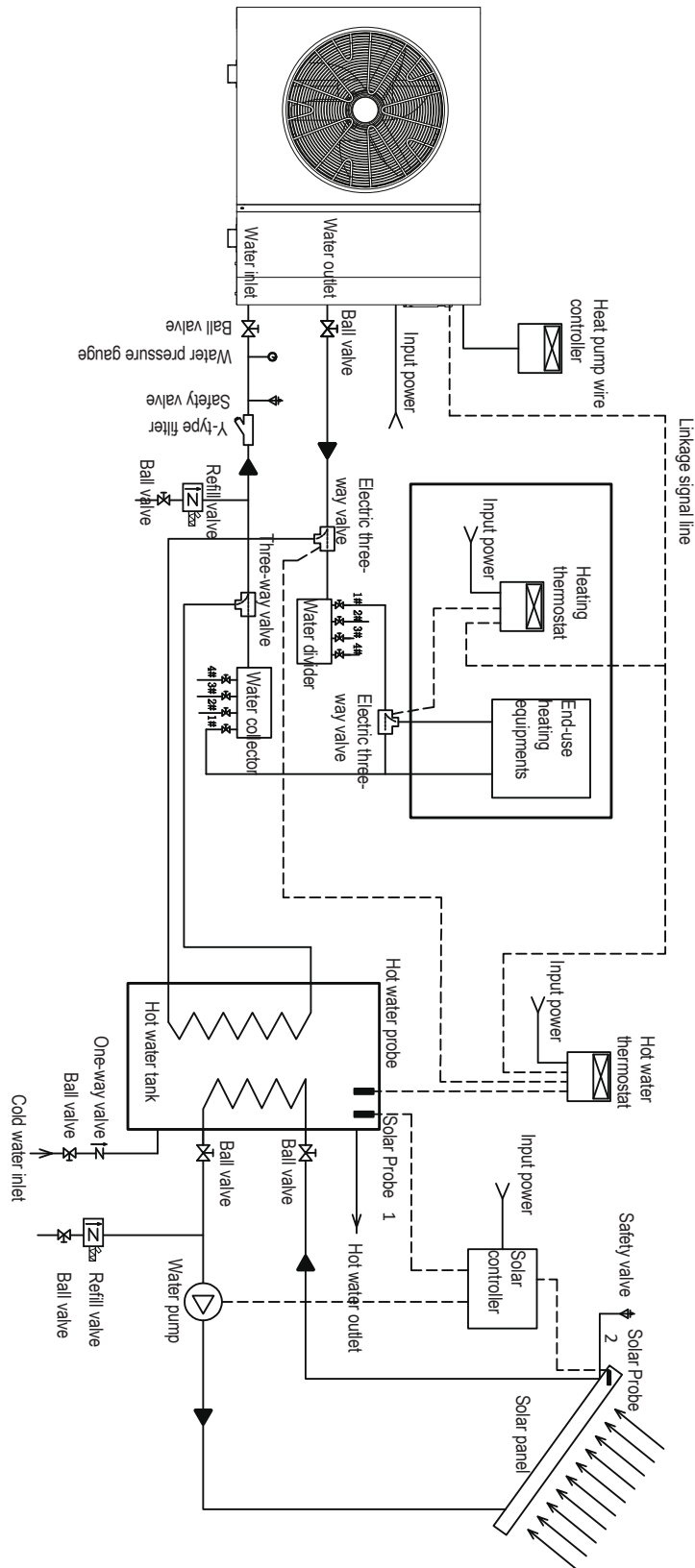

Remark:

1. The water divider and water collector are used for water distribution when multiple end-use heating equipments are installed at the same time.
2. After connected to the linkage signal line, each individual thermostat can control the operation or shutdown of the heat pump. If didn't connect to the linkage signal line, the heat pump will operate until the shutdown conditions of the heat pump are met (whether the end-use heating is using or not).
3. The DHW function only available under the heating mode.(PS:If sufficient hot water is produced by solar energy, the heat pump can be converted to cooling mode.)
4. Adding a hot water thermostat can control the temperature of the hot water tank, if only the heat pump is used for heating, the maximum DHW temperature can reach the set temperature of the heat pump at most.
- 5.If the solar energy is sufficient, the DHW can be heated to a higher temperature through the solar panel.
- 6.The schematic diagram mainly provides the necessary pipeline accessories. Other accessories may need to be added according to the actual site engineering installation situation.

### 3.3 General Applications :

#### 3.3.5 Heating + hot water function (Solar Panel-optional)

This application is recommended for using heating (floor/radiator/fan coil) and high temperature DHW purposes with a solar panel heating source.

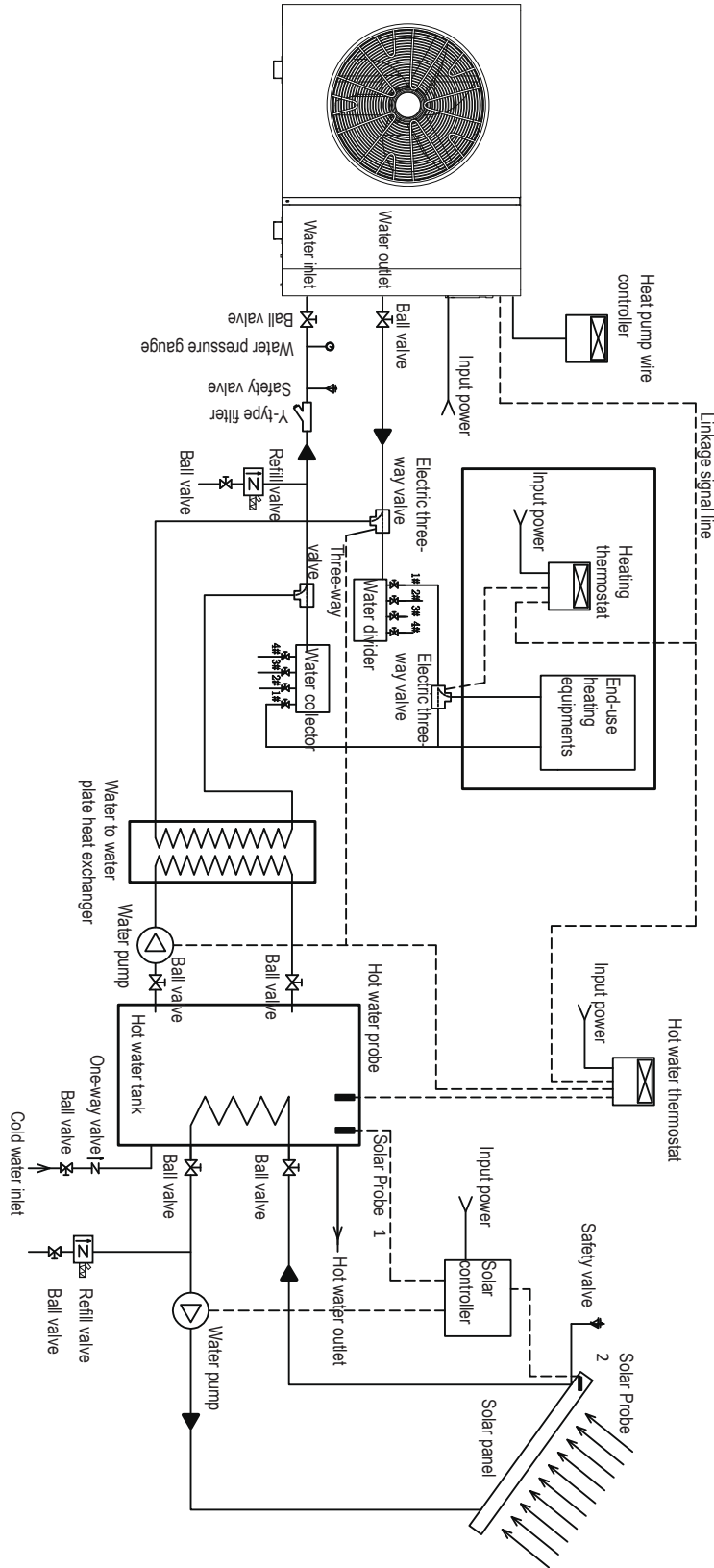

Remark:

1. The water divider and water collector are used for water distribution when multiple end-use heating equipments are installed at the same time.
2. After connected to the linkage signal line, each individual thermostat can control the operation or shutdown of the heat pump. If didn't connect to the linkage signal line, the heat pump will operate until the shutdown conditions of the heat pump are met (whether the end-use heating is using or not).
3. The DHW function only available under the heating mode.(PS:If sufficient hot water is produced by solar energy, the heat pump can be converted to cooling mode.)
4. Adding a hot water thermostat can control the temperature of the hot water tank, if only the heat pump is used for heating, the maximum DHW temperature can reach the set temperature of the heat pump at most.
- 5.If the solar energy is sufficient, the DHW can be heated to a higher temperature through the solar panel.
- 6.The schematic diagram mainly provides the necessary pipeline accessories. Other accessories may need to be added according to the actual site engineering installation situation.

Remark:

\* The installation diagram is for reference only! Before installation, please consult the technicians of relevant disciplines to design an appropriate construction scheme according to the site.

\* The accessories required for installation shall be purchased according to the actual construction.

\* When there are multiple ends, the same waterway design is recommended to avoid too large difference in end use effects.

\* When the machine is running, condensed water will be generated. Please pay attention to the discharge of condensed water.

### 3.4 Electrical wiring



#### Notice

- 1) The unit shall use special power supply, and the power supply voltage must meet the rated requirements.
- 2) The power supply circuit of the unit must have a grounding wire. The power grounding wire must be reliably connected with the external grounding wire, and the external grounding wire is effective.
- 3) The wiring construction must be operated by professional installation personnel.
- 4) The power supply of the unit needs to be equipped with leakage protector (not standard, need to be purchased separately).
- 5) The layout of power line and signal line shall be reasonable, and the strong current and weak current wires shall be separated without mutual interference.
- 6) After all wiring construction is completed, the power supply can be connected only after careful inspection.

Model	Voltage(V)	Fuse(C-curve)	Max current(A)	Cable section*
NT-9IISE	380-415V,3N~,50Hz	20A	13.3A	5*2.5mm <sup>2</sup>
NT-12IISE	380-415V,3N~,50Hz	25A	14.3A	5*2.5mm <sup>2</sup>
NT-17IISE	380-415V,3N~,50Hz	30A	17A	5*4mm <sup>2</sup>
NT-22IISE	380-415V,3N~,50Hz	30A	17.5A	5*4mm <sup>2</sup>

\*Type of fuse:(1)Rated voltage: 250V AC. (2)Low breaking capacity. (3) Time-lag fuse (T).

**\*\* The power cable shall not be inferior to the chloroprene rubber sheathed flexible cable (No. 57 cable in the IEC 60245)!**

### 3.5 Wire system connection and wiring diagrams

The machine is provided with a terminal connecting the indoor temperature controller, which is convenient for the indoor temperature controller to automatically control the startup and shutdown of the machine.

- 1) Remove the jumper on the “LS” terminal block.
- 2) Connect the output signal line of the indoor temperature controller to the “LS” terminal block.
- 3) After the machine is powered on, set the wire controller to the startup state and the required operation mode, such as heating mode or cooling mode.
- 4) When the indoor temperature controller is started, if the room needs heating or cooling, the indoor temperature controller will output a signal to the machine, and the machine will start automatically. If the indoor temperature controller is turned off, or when the indoor temperature reaches the set value, the indoor temperature controller will turn off the output signal and the machine will turn off automatically.

#### Attention:

- 1) The output signal of the indoor temperature controller is a passive signal, and the voltage value shall not exceed DC5V.
- 2) If it is not necessary to connect the indoor temperature controller, it is necessary to keep the jumper connection on the “LS” terminal block, otherwise the machine will not start.

#### Wall-mounting the remote control :

- Step 1: Take the wire controller off the machine. Pay attention to the communication wires connected to the wire controller and separate them carefully.
- Step 2: Select the installation location of the wire controller, pay attention to the wiring length between the wire controller and the unit should not exceed 4.5 meters.
- Step 3: Install PVC pipe between the wire controller and the unit, and the communication line extends through the PVC pipe to the installation point of the wire controller .
- Step 4: Remove the hook behind the wire controller.
- Step 5: Drill two vertically oriented holes at eye height: 13 mm from center to center.
- Step 6: Fasten the hook to the wall and connect the wire controller to the hook.

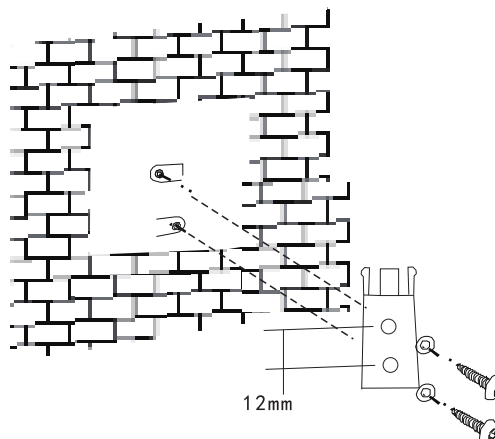

\*FAN2: Only for dual fan models.

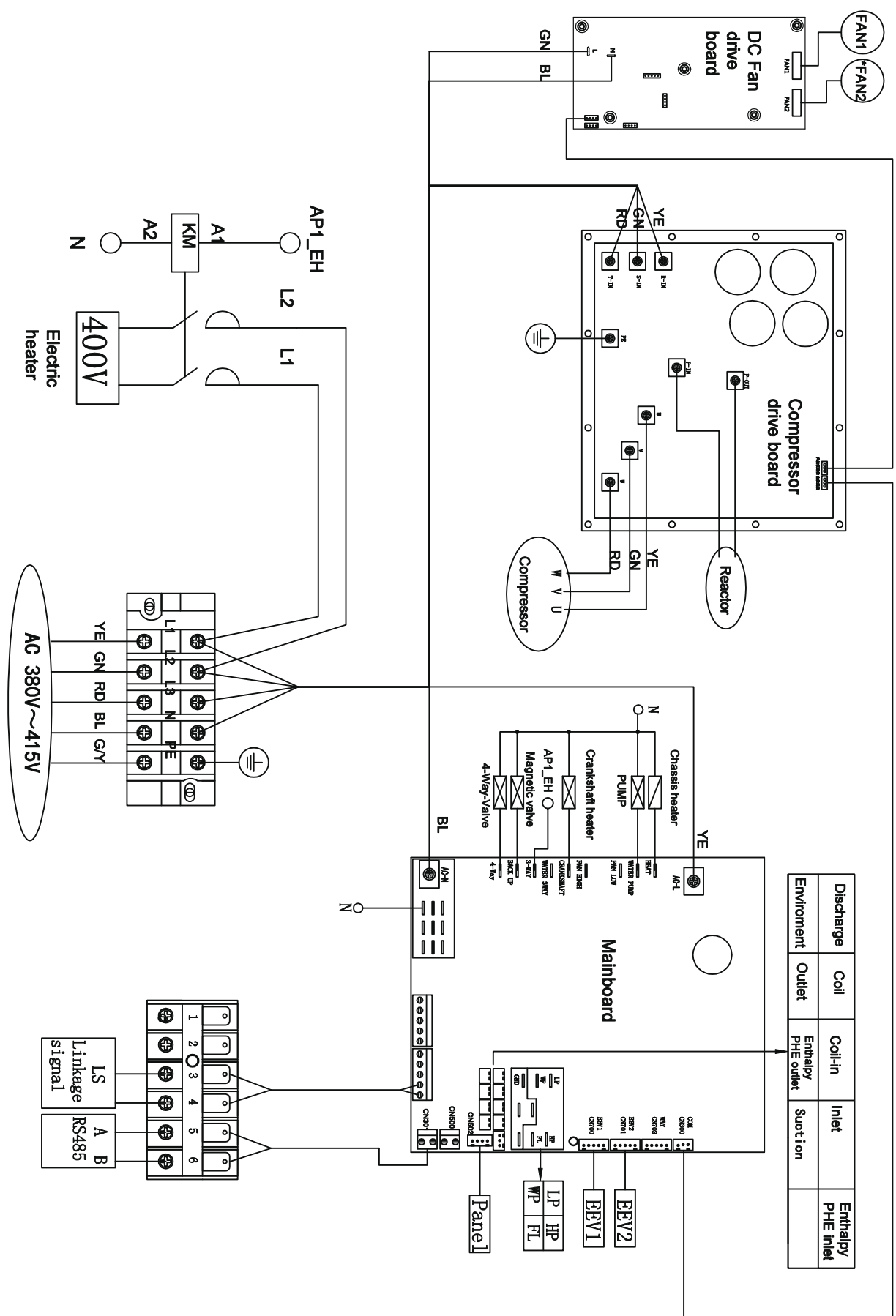

Discharge	Coil	Inlet	Enthalpy PHE Inlet
Environment	Outlet	Enthalpy PHE outlet	Suction

## 4. Operation and Use

### 4.1 Display interface introduction

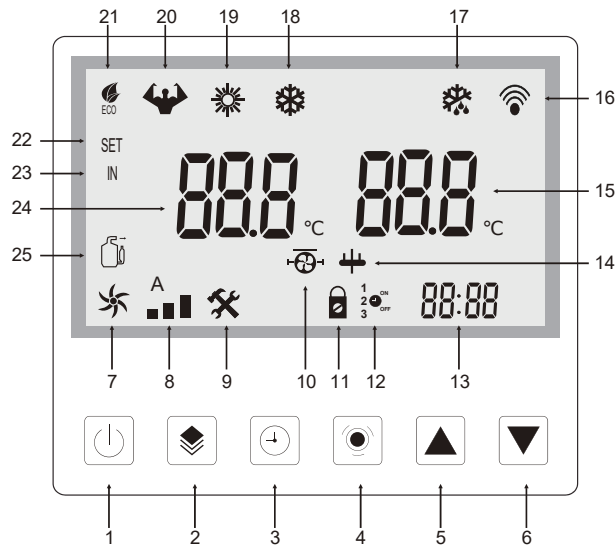

No.	Functions	No.	Functions	No.	Functions
1	Power On/Off	9	Fault indicator	18	Cooling mode
2	Mode	10	Water pump indicator	19	Heating mode
3	Time	11	Lock	20	Powerful mode
4	Set	12	Timer On/Off	21	Energy saving mode
5	Up	13	Time display	22	Set indicator
6	Down	14	Four-way valve	23	Inlet water temperature icon
7	Fan indicator	15	Outlet water temperature	24	Inlet water temperature
8	Fan speed indicator	16	Wifi indicator	25	Compressor indicator
		17	Defrosting state		

## 4.2 Operating instructions

### 4.2.1 Key lock and unlock

Locked during Power Off state

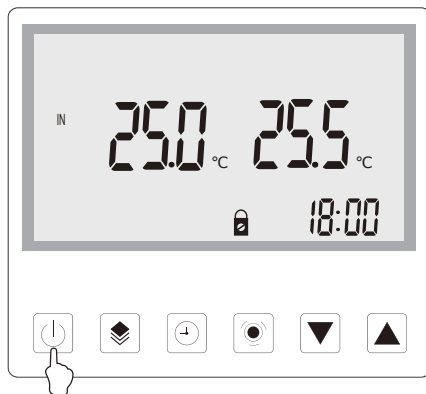

Long press for 5 seconds



Lock indicator disappears

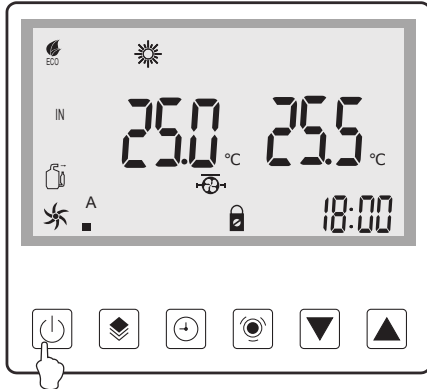

## Locked during operation state

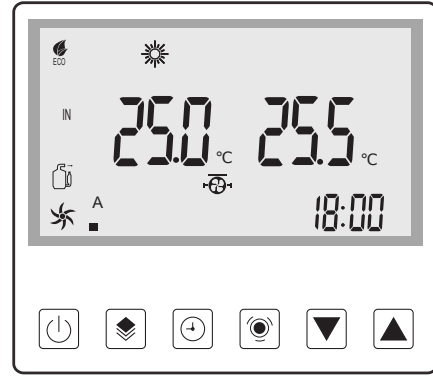

Long press for 5 seconds



Lock indicator disappears

1.Lock: The screen will be locked when press “” for 5 seconds, or there is no operation for 60 seconds(Purpose: to prevent children from playing). And the screen will display “”, any operation is invalid at this time.

2.Unlock: Press“”for 5 seconds until “” disappears.

## 4.2.2 Power On/Off

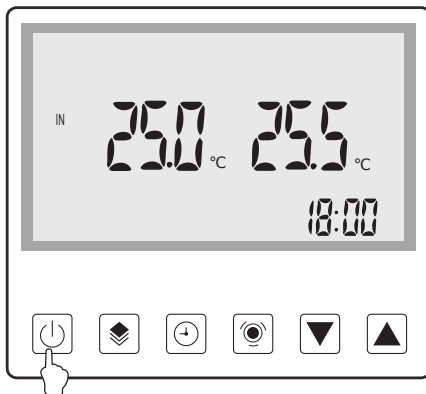

Power Off

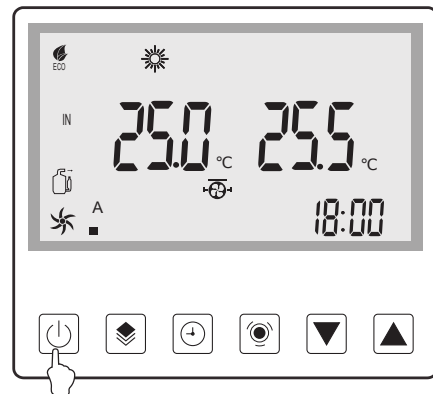

Power On

1.Power On: Press “” to turn on the heat pump.  
( In the Power On state, the screen will display the operating mode)

2.Power Off: In the main interface, press“”to turn off the heat pump.  
( In the Power Off state, the operating mode won't be displayed)

### Tips:

In other interfaces, press“” return to the main interface.

### 4.2.3 Switching the operating mode

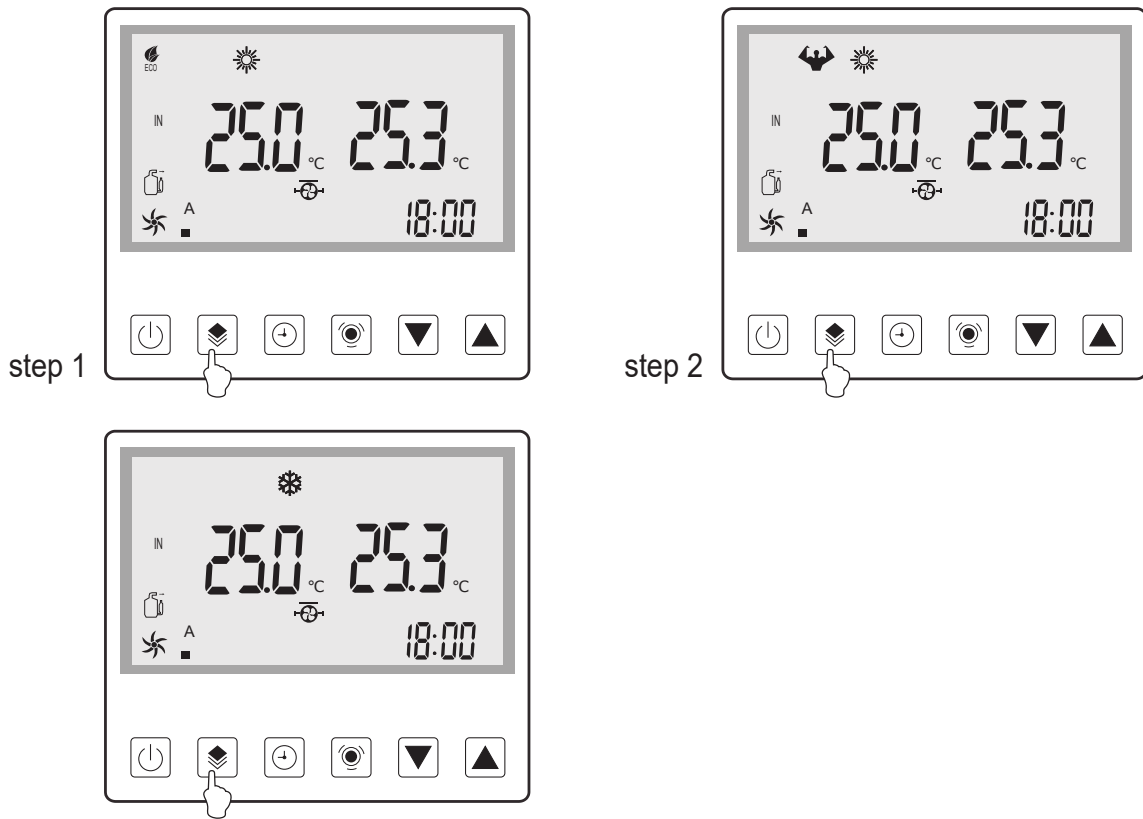

Make sure the screen is unlocked , in the main interface,

**step 1** : Press “  ” for 3 seconds to enter the working mode of the machine.

**step 2** : Press “  ” to select modes, and the order of different modes will pop up:

  Energy Conservation Heating Mode →   Powerful Heating mode →  Cooling Mode

Tip:  
Defrosting mode.

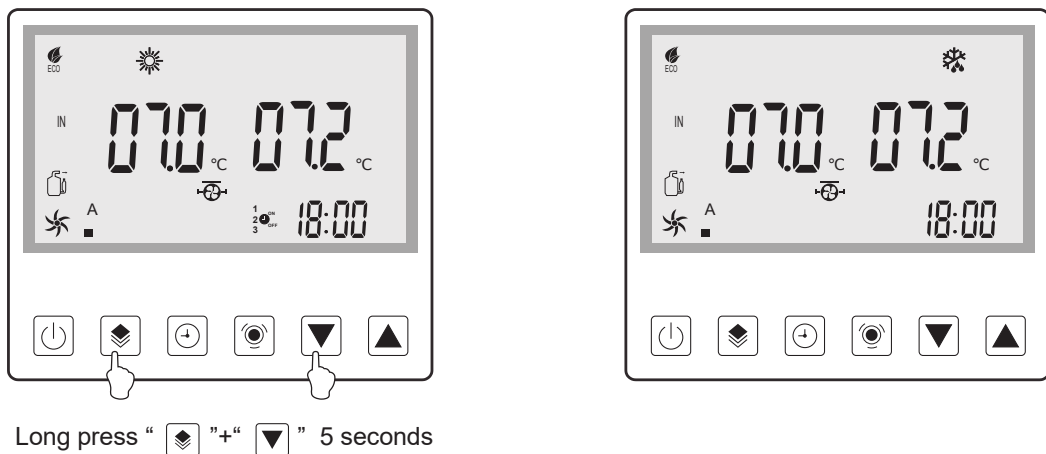

In the unlocked heating mode,press“  ”+“  ” 5 seconds to enter manual defrosting mode.

**Remarks:** The defrosting mode is only used under special circumstances. For example, the outdoor heat exchanger has frosted before startup.

## 4.2.4 Temperature adjustment

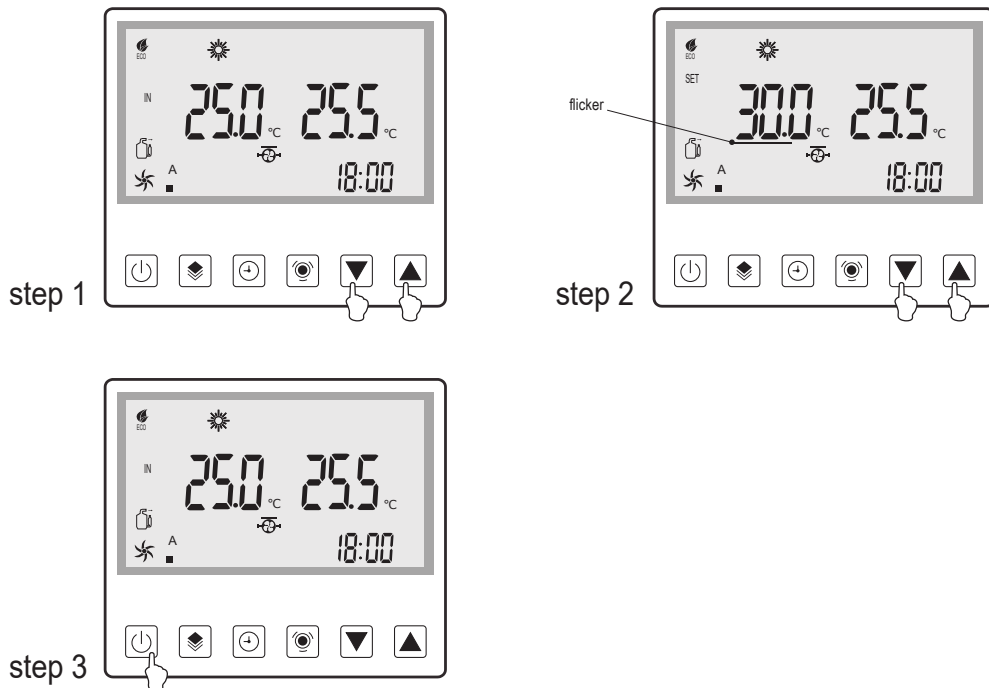





**step 1:** In the unlocked main interface, press the “ ▲ ” key or “ ▼ ” .

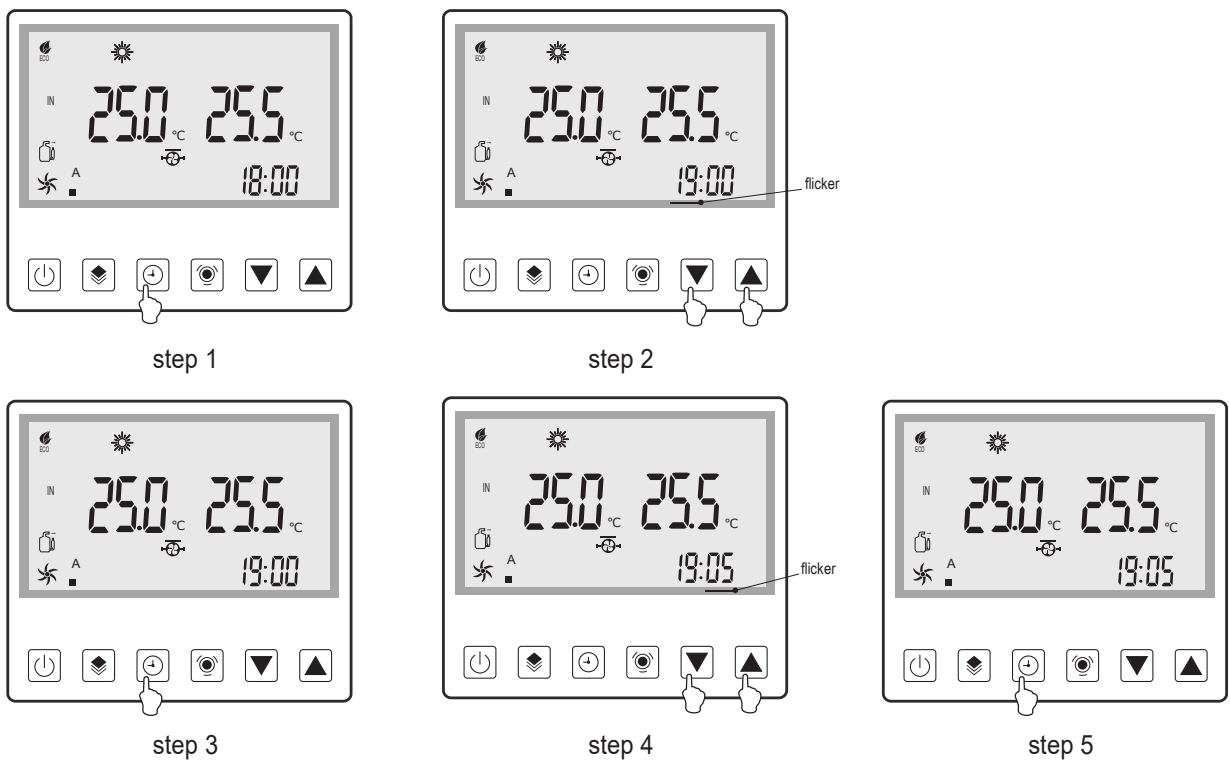

**step 2:** The water inlet temperature icon will flash, press the “ ▲ ” key or “ ▼ ” key to adjust the figure.

**step 3:** Press the “ ⏻ ” key to confirm and back to the main interface.

## 4.2.5 Time adjustment



**step 1:** In the main interface, press “” key to enter the real-time clock setting interface, the digits in the hour part will flash, press the “” key or “” key to set the hour of the real-time clock.

**step 2:** After setting the hour part, press the “” key again, the hour part will stop flashing, and the digits in the minute part will flash. At this time, press the “” key or “” key to set the minutes of the real-time clock .



**step 3:** After the minute part is set, press the “” key again to confirm the real-time clock setting and return to the main interface.

(Press the “” can also confirm the current real-time clock setting value and return to the main interface )

## 4.2.6 Timer Operation Procedure

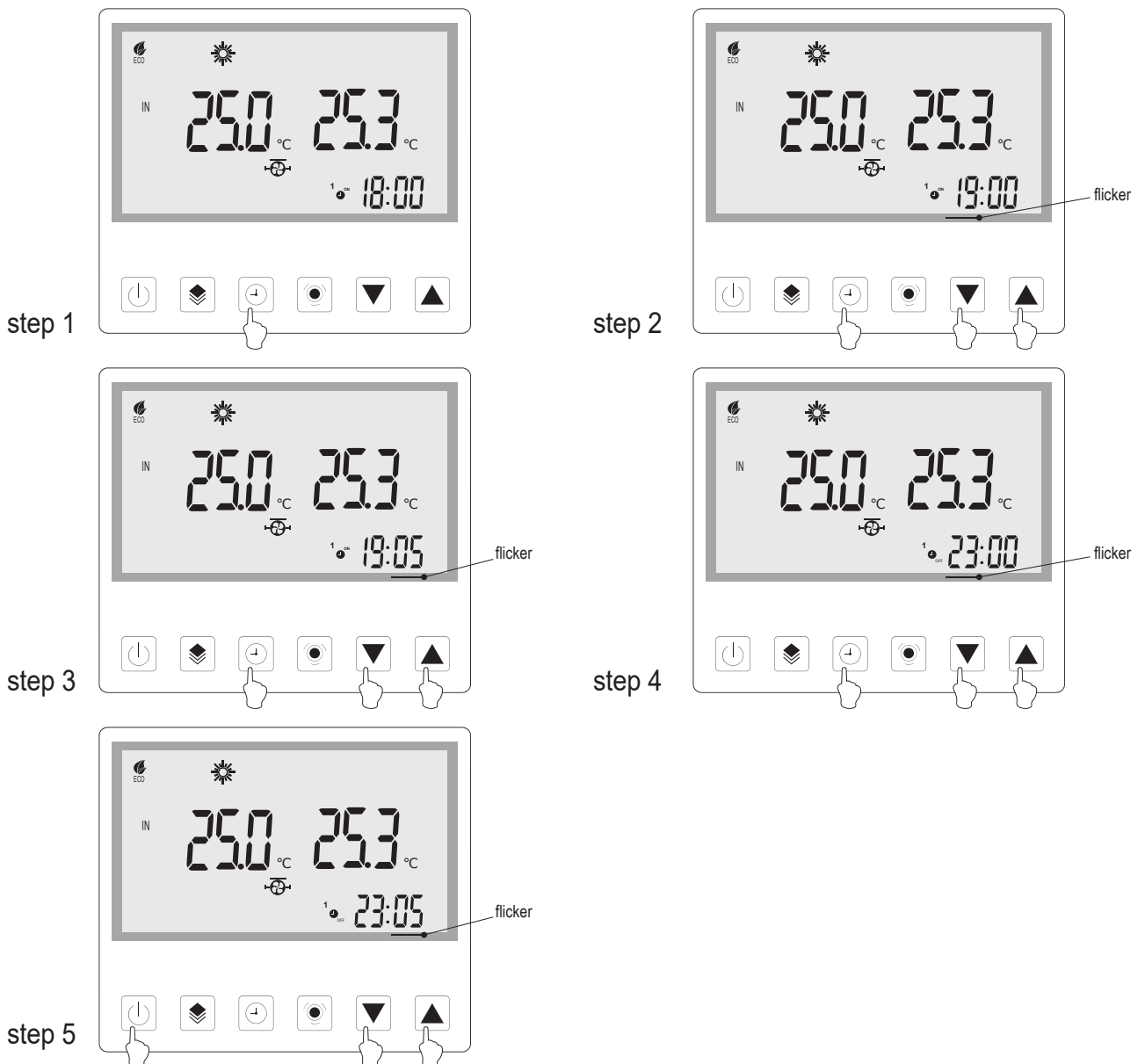



### (1)Single group Timer Operation Procedure





**Step 1:** Setting up the first group of timer . Long press “” for 5 seconds, when “ 18:00 ” lights up, it enters the start time setting for the first group of timer .

**Step 2:** “Hours” digits flashing, press “” or “” to adjust “Hours”. Press “” to confirm the setting value and switch to Minutes setting.

**Step 3:** “Minutes” digits flashing, press “” or “” to adjust “Minutes”. Press “” to confirm the setting value and enter the stop time setting of the first group of timers.



**Step 4:** The “ 18:00 ” lights up, “Hours” digits flashing, press “” or “” to adjust “Hours”. Press “” to confirm the setting value and switch to Minutes setting.

**Step 5:** “Minutes” digits flashing, press “” or “” to adjust “Minutes”. Press “” confirm it and return to the main interface.

**Example:** If a timer is set to turn on at 8:15, turn off at 21:00, the machine will automatically turn on at 8:15, and turn off at 21:00 everyday.

## (2) Multi group Timer Operation Procedure

This is for setting up the second, and third group of timer.

After finished setting up the first timer, do not press “”, press “” to enter second group of timer setting. After “ 18:00 ” lights up, follow steps 1 to 4 from first group of timer setting to set up the other groups of timer.

## 4.2.7 Cancel timer function

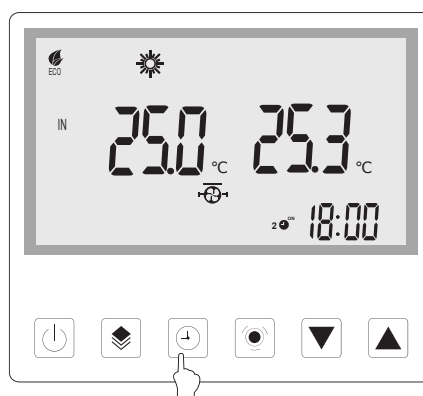

In the unlocked state, press “” for 3 seconds to cancel the timer function.



## 4.2.8 Parameter query and setting



**Warning:** “” is used to set the key parameters of the heat pump, which is specially operated by certified technicians. The machine might be damaged if an end user operate this function.

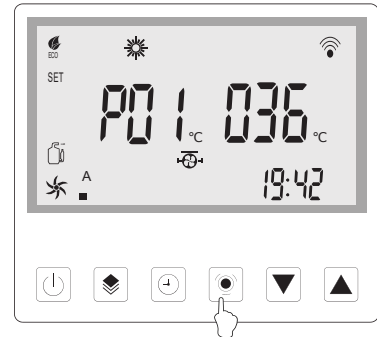

### “P”parameter query and setting

**Step 1:** Press “” to enter the "P parameter setting" menu . (It can also be set when the machine is off).



**Step 2:** Press “” or “” to browse and query the parameters of heat pump. And then press “” to select the parameter.

**Step 3:** Modify the parameter by “” or “” .

**Step 4:** Save the setting parameter after press “” , then press “” to return to main interface.(If there is no operation for 60s in the parameter setting interface, it will automatically exit and return to the main interface).

Code	Description	Default	Scope	Remark
P01	Water inlet temperature setting in Heating Mode	40°C ( 104 °F)	8°C~P09 ( 46°F~P09 )	
P02	Water inlet temperature setting in Cooling mode	12°C (80°F)	8~28°C ( 46~82°F )	
P03	Reserve			
P04	Adjustment of temperature difference before restart	1°C (33°F)	1~18 °C ( 33~64°F )	
P05	Heat pump ON/OFF when temperature reached 1=ON;0=OFF	1	0 or 1	
P06	Reserve			
P07	Ambient temperature of auxiliary electric heater startup	-15°C (5°F)	-30~10°C (-22 ~50°F )	
P08	Reserve			
P09	Adjustment of P01 maximum value	55°C ( 131°F )	15~60°C ( 59~140°F )	
P10	Reserve			

### “C”parameter query

Parameter browse, press “” to enter the parameter query

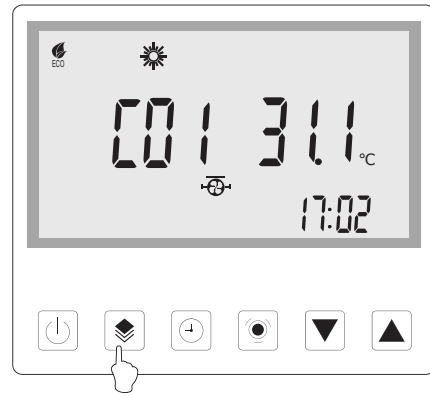

Code	Description	Scope	Unit	
c01	Outdoor ambient temperature		°C	
c02	Outside coil temperature		°C	
c03	Exhaust temperature		°C	
c04	Return air temperature		°C	
c05	Reserve		°C	
c06	Reserve		°C	
c07	Inside coil temp (after throttle)		°C	
c08	Water inlet temperature		°C	
c09	Water outlet temperature		°C	
c10	Economizer inlet temperature		°C	
c11	Economizer outlet temperature		°C	
c12	Reserve			
c13	Sensor failure			
c14	System failure			
c15	Driver failure			
c16	Signal output			
c17	Running status			
c18	AC voltage		V	
c19	DC voltage		V	
c20	Actual frequency		Hz	
c21	Main EEV open degree			

Code	Description	Scope	Unit	
c22	Aux EEV open degree			
c23	Heat pump current		A	
c24	Compressor current		A	
c25	DC FAN1 Speed		Rpm	
c26	Compressor target frequency		Hz	
c27	DC FAN2 Speed		Rpm	
c28	Master control software		version	
c29	Driver software version		version	
c30	Wire controller software		version	

## 4.3 Error codes and troubleshooting

4.3.1 When the machine displays the following code, the machine may be in a protected or faulty state. You can troubleshoot according to the following suggestions.

Code	Description	Possible causes	Inspection and troubleshooting
E03	Water flow failure	The water pump is not started	Check whether the water pump is installed correctly and can be started
		The water flow is too small or the pipeline is blocked	Check whether the water pipeline is not drained or blocked
		The water flow switch wiring is abnormal or damaged	Check the water flow switch wiring or replace the water flow switch
		The water inlet and outlet pipes are connected reversely	Check if the piping is installed correctly
E05	High pressure protection	The high pressure switch is damaged	Replace the high pressure switch
		Insufficient water flow due to air in the pipeline	Drain the pipe air
		The water inlet temperature sensor is not installed properly, resulting in higher water temperature than actual	Install the water inlet temperature sensor correctly
		The circulating water pump is abnormal, resulting in small water flow	Check or replace the circulating water pump
		Excessive refrigerant charge	Discharge excess refrigerant
		The water heat exchanger is seriously fouled, resulting in poor heat exchange	Regularly clean the water heat exchanger
E06	Low pressure protection	Throttling components blocked	Check or replace throttling components
		Dirty surface of evaporator fins	Clean the evaporator fins
		The low pressure switch is damaged	Replace the low pressure switch
		Insufficient refrigerant (leakage)	Check the leakage position, repair it, re-vacuum and charge the refrigerant according to the refrigerant type and weight shown on the nameplate.

Code	Description	Possible causes	Inspection and troubleshooting		
E09	connection failure between control main Program board and controller	/	Please contact the supplier		
E10	connection failure between driver and main Program board	/			
E11	After throttle temperature sensor failure	/			
E12	Exhaust temperature too high	The water temperature is too high during heating	Check whether the water temperature sensor is installed in place		
		Insufficient refrigerant (leakage)	Check the leakage position, repair it, re-vacuum and charge the refrigerant according to the refrigerant type and weight shown on the nameplate.		
		The water heat exchanger is seriously fouled, resulting in poor heat exchange	Regularly clean the water heat exchanger		
		The circulating water pump is abnormal, resulting in small water flow	Check or replace the circulating water pump		
E15	Water inlet sensor failure	Sensor short circuit or open circuit	Check/replace the sensor		
E16	Outside coil sensor failure				
E18	Exhaust sensor failure				
E21	Ambient temperature failure			The sensor head is loose	Check the sensor head condition
E27	Water outlet sensor failure				
E29	Return air temperature sensor failure				
E22	Vast temperature variations between inlet and outlet	Low water flow	Check whether the pump is running normally and whether the waterway is blocked		
E23	Water outlet temperature lower in Cooling Mode	/	Confirm whether the actual water temperature is too low. If not, check the temperature sensor for damage		
E30	Protection during the outdoor ambient temperature is too low	/	Confirm whether the actual ambient temperature is too low. If not, check the temperature sensor for damage		
E31	Auxiliary electric heating overload protection	/	Please contact the supplier		
E32	Water outlet temperature over in Heat Mode	/	Please contact the supplier		
E33	Outside coil temperature over in Cooling Mode	/	Please contact the supplier		
E34	Compressor drive failure	The compressor wiring is abnormal	Check whether the wiring is normal		
		Compressor UVW phase sequence error	Wire the wires in the correct order		
E35	Compressor current over	The compressor is overloaded, causing the compressor phase current to exceed the standard	Lower the water temperature and then start the machine. If the water temperature is not high; check whether the radiator temperature is too high and the heat dissipation is poor		
E36	Compressor output failure	/	Please contact the supplier		
E37	IPM current failure	Abnormal drive board	Power on again and the fault is eliminated. If the fault still occurs after multiple attempts to start, it is recommended to replace the drive board		
E39	Module emergency shutdown (including high voltage alarm and PFC failure)	/	Please contact the supplier		

#### 4.3.2. The compressor does not start.

When the compressor does not start, it may be due to the following reasons:

- \* The machine is not turned on, please press the key to start the machine.
- \* The water temperature has reached the set temperature, and the machine stops working. Wait for the water temperature to change to a certain value and then restart the work automatically.
- \* The machine is not enough for 3 minutes. Due to the compressor's own protection requirements, after the shutdown, it is necessary to wait at least 3 minutes before restarting the compressor. This is a normal protection measure.
- \* The machine is in a fault or other protection state. For details, see the description in the table at point 1.

### 4.3.3. The fan is not running.

When the fan does not start, it may be due to the following reasons:

- \* The machine is not turned on, please press the key to start the machine
- \* If the water temperature has reached the set temperature or above, the machine stops heating. After the water temperature drops, heating can be resumed automatically.
- \* The machine is in a fault or other protection state. For details, see the description in the table at point 1.

## 5. Maintenance and Inspection

- \* Check the water inlet and drainage often. The water and air inflow into the system should be sufficient so that its performance and reliability does not get compromised. You should clean the pool filter regularly to avoid damage to the unit caused by clogging of the filter. • The area around the unit should be spacious and well ventilated. Clean the sides of the heat pump regularly to maintain good heat exchange and to save energy.
- \* Check if all processes in the unit are operational and pay special attention to the operation pressure of the refrigerant system.
- \* Check the power supply and cable connections regularly. Should the unit begin to function abnormally or should you notice a smell from an electrical component, arrange for timely repair or replacement.
- \* Winterizing : make sure to drain all the water from the heat pump and other systems in order to prevent frost damage. Damage caused by freezing is not covered by the warranty.
- \* You should also purge the water if the unit will not work for an extended period of time. You should check all parts of the unit thoroughly and completely fill the system with water before turning it on again afterwards.

## 6. Warranty

Thank you for purchasing our heat pump. To be announced by local agent/distributor.  
For detailed warranty policy please contact local agent/distributor directly.

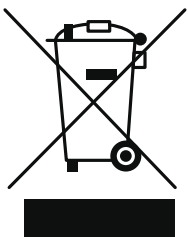

The symbol depicting a crossed-out waste bin ,that this product, at the end of its useful life, must be handled separately from domestic waste, must be taken to a recycling centre for electric and electronic devices or handed back to the dealer when purchasing an equivalent appliance.



